



UNIVERSITÀ DI PISA

Near-Field Focused Antennas for Wireless Communications and Power Transfer

Paolo NEPA

Dept. of Information Engineering
University of Pisa

Via G. Caruso 16, I-56122, Pisa, Italy

p.nepa@iet.unipi.it



International Spring School on ***“Electromagnetics and emerging technologies for pervasive applications: Internet of Things, Health and Safety”***



18th–20th April, 2016, Bologna, Italy





Agenda

- ✓ NEAR-FIELD FOCUSED ANTENNAS (NFFAs): CHARACTERISTIC PARAMETERS AND PROPERTIES
- ✓ BASIC DESIGN CRITERIA
- ✓ MICROWAVE NEAR-FIELD APPLICATIONS
- ✓ ADVANCED SYNTHESIS TECHNIQUES
- ✓ TECHNOLOGIES FOR NFF ANTENNAS: EXAMPLES
- ✓ CONCLUSIONS

Focusing: well-known concept in optics

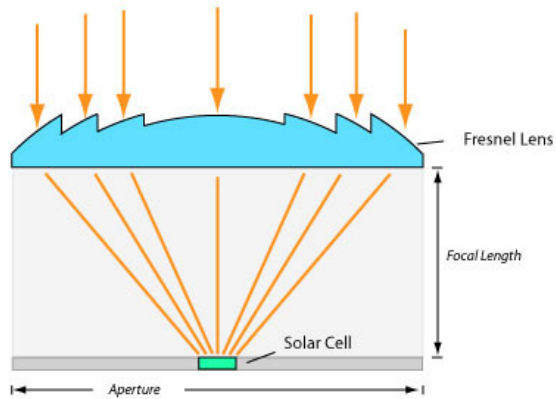
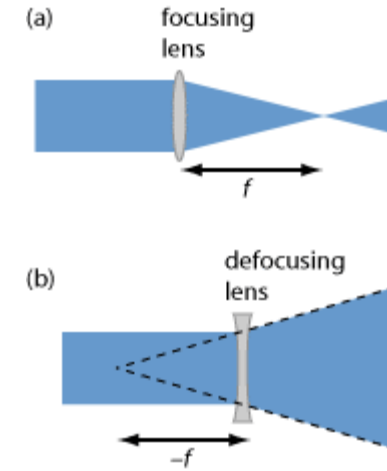
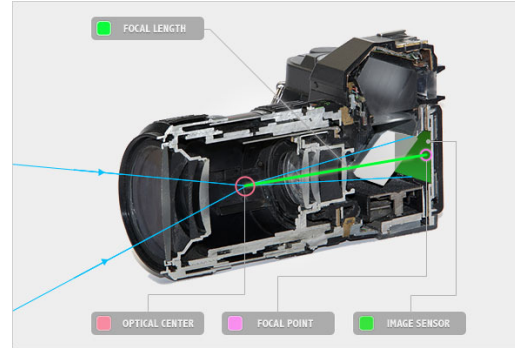

In Concentrating Photovoltaics (CPV), a large area of sunlight is focused onto the solar cell

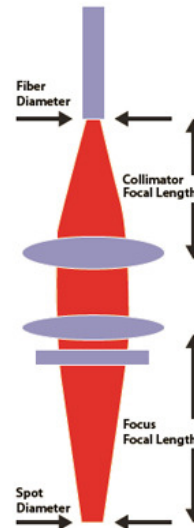

..... burning ants or paper with a magnifier glass

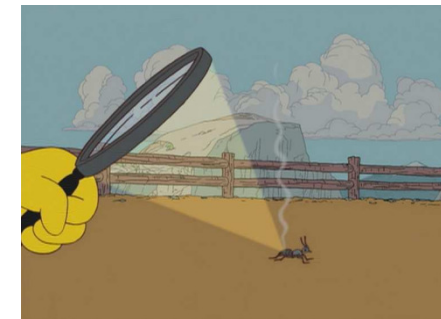



From optics to mm-waves and THz regime

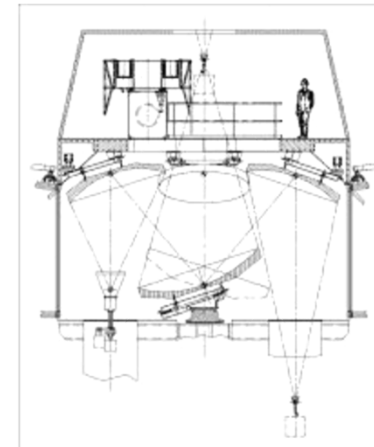
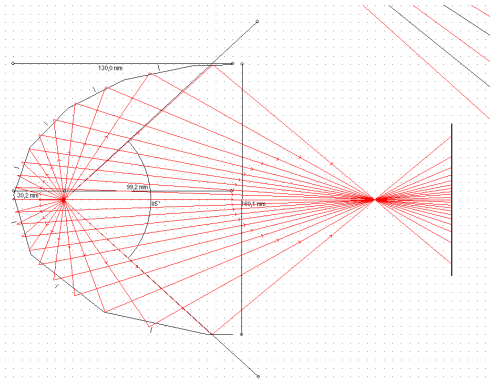
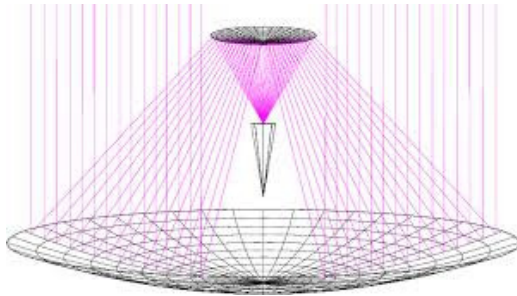
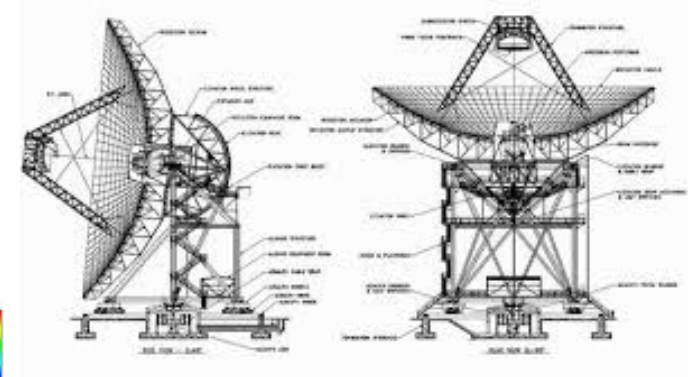
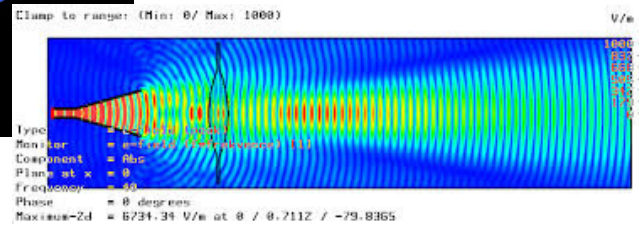
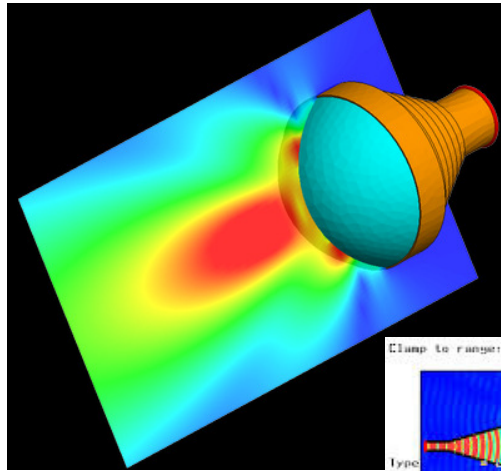

Focusing the electromagnetic field at a point in the antenna near-field region (the focal point) allows to increase the electromagnetic power density in a size-limited spot region close to the antenna/array aperture.

Focusing: from optics to microwaves

At the microwave frequencies and for short-range wireless systems (e.g. indoor communication systems), the antenna size cannot be much larger than the wavelength

The basic idea is to control the phase of the radiation sources on the antenna aperture (array element currents or equivalent surface currents) in such a way that their field contributions sum constructively at the assigned focal point located in the antenna radiative near-field (NF) region

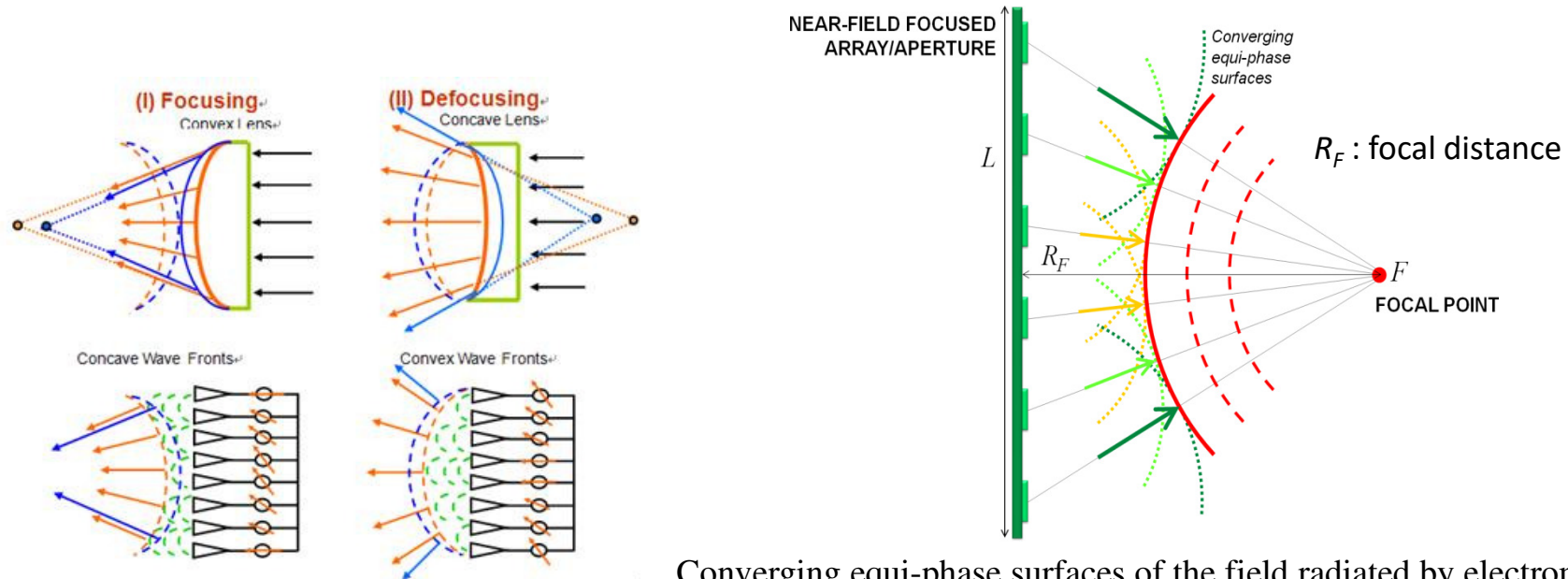

Converging equi-phase surfaces of the field radiated by electromagnetic sources that are located on a planar aperture and focused at a focal point, F , in the antenna near-field region.



Agenda

- ✓ NEAR-FIELD FOCUSED ANTENNAS (NFFAs): CHARACTERISTIC PARAMETERS AND PROPERTIES
- ✓ BASIC DESIGN CRITERIA
- ✓ MICROWAVE NEAR-FIELD APPLICATIONS
- ✓ ADVANCED SYNTHESIS TECHNIQUES
- ✓ TECHNOLOGIES FOR NFF ANTENNAS: EXAMPLES
- ✓ CONCLUSIONS

Focusing in the radiative NF region

Let us assume $L > \lambda$

The reactive near-field (NF) region is located close to the antenna, up to a distance

$$r_{NF} \approx 0.62\sqrt{L^3 / \lambda}$$

$$(r_{NF} / L \approx 0.62\sqrt{L / \lambda} > 1, \text{ if } L > 2.6\lambda)$$

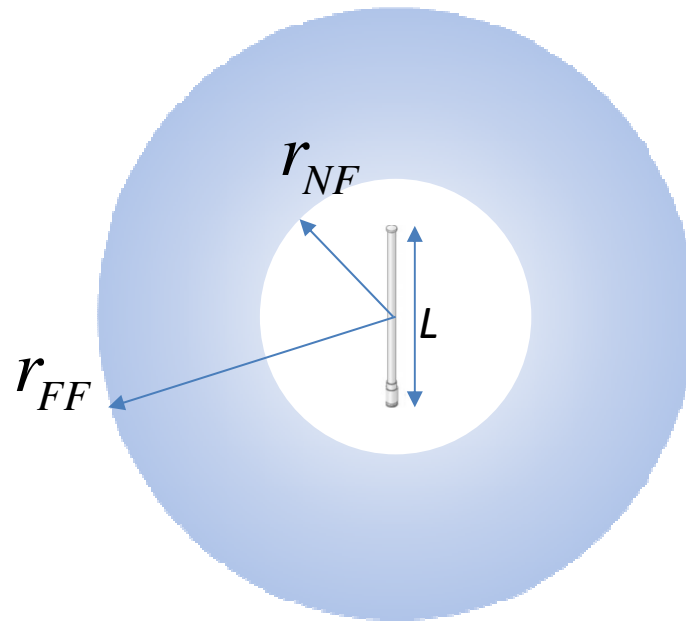

Radiative near-field region or Fresnel region

$$r_{NF} < r < r_{FF}$$

The far-field (FF) region starts at $r_{FF} \approx 2L^2 / \lambda$

In the FF region (where the parallel ray approximation can be used), the field decreases as $1/r$ (20dB/decade) and the radiation pattern does not change with distance (typical antenna parameters are defined in the FF region)

Planar NFF array: numerical results

An 8×8 array of microstrip circularly polarized (CP) patches at 2.4 GHz.
 Inter-element distance $= 0.8\lambda$, $L = 6.4\lambda = 80\text{cm}$, $R_F = 8.2\lambda = 1\text{m}$

For the NFF array, the **normalized focal distance** is $\gamma = R_F / (2L^2 / \lambda) = 0.1$

(for the unfocused version of the array: $\gamma \gg 1$ and all patches are fed in phase).

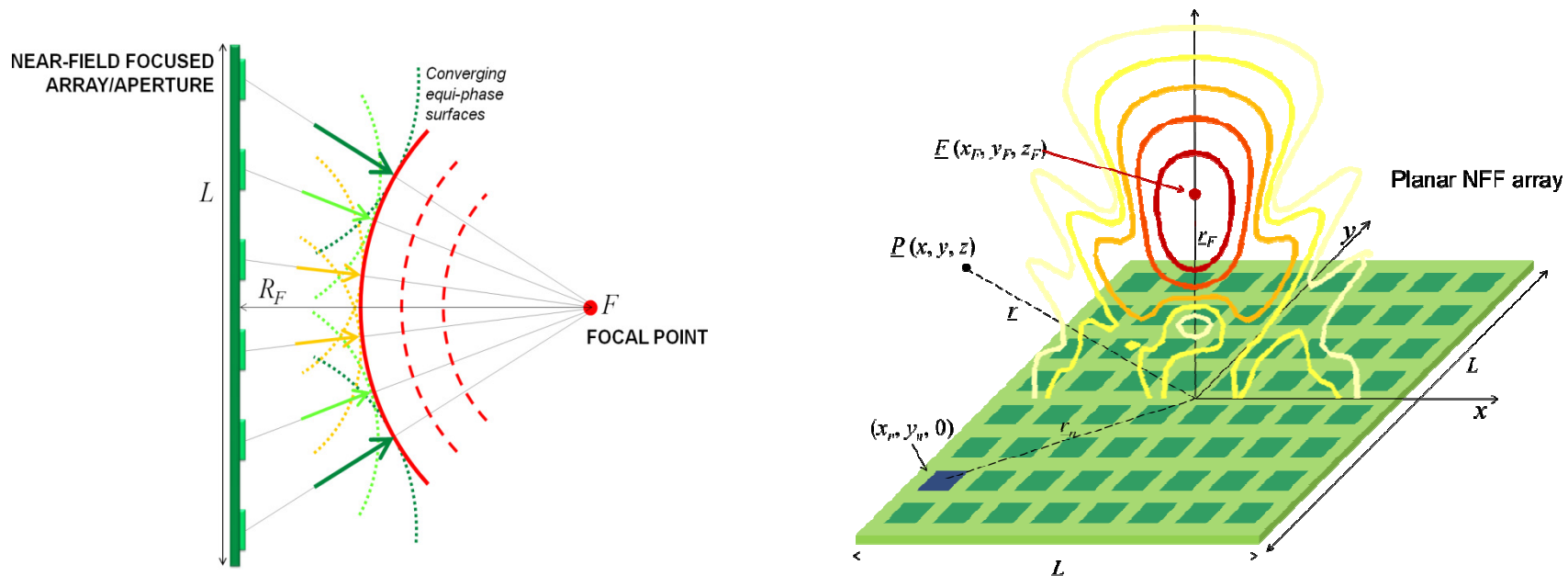

Focusing advantages

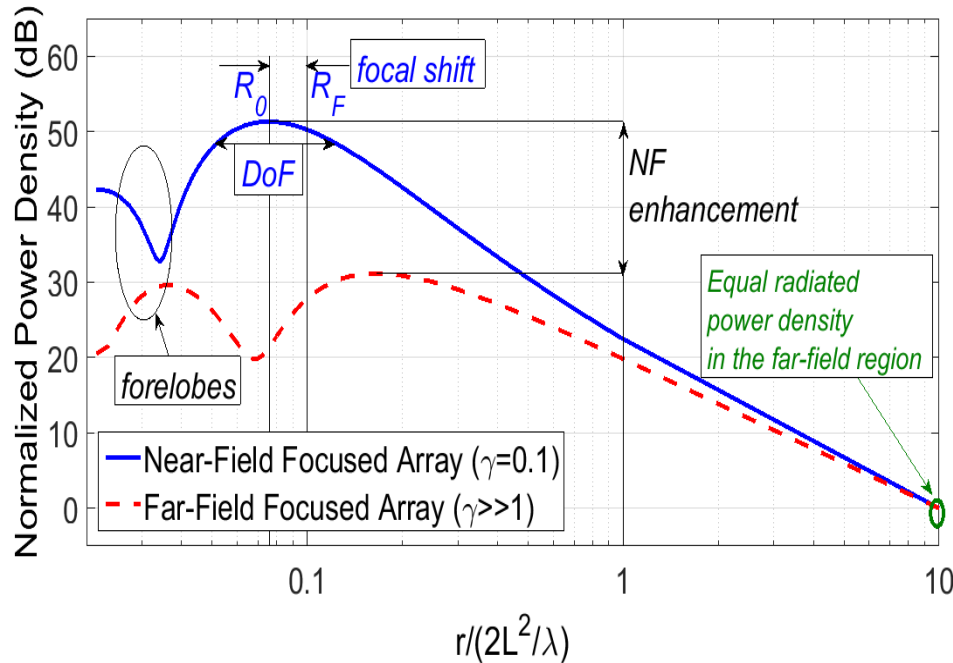

Normalized power density (dB) radiated along the direction perpendicular to the array surface (on-axis power density). The distance from the array surface (r) is normalized to the far-field region boundary ($2L^2/\lambda$).

DoF (depth of focus): the range between the -3 dB axial points around the point of maximum power density, along the direction normal to the antenna aperture

$$\gamma = R_F / (2L^2/\lambda) = 0.1$$

R_F : focal distance (1m)

R_0 : distance from the array surface of the field amplitude peak (77.5cm)

$R_F - R_0$: **focal shift** (22.5cm)

Note: each curve is normalized to its value at $r=10 \times 2L^2/\lambda$

Focusing advantages

Note: each curve is normalized to its maximum value in the near-field region.

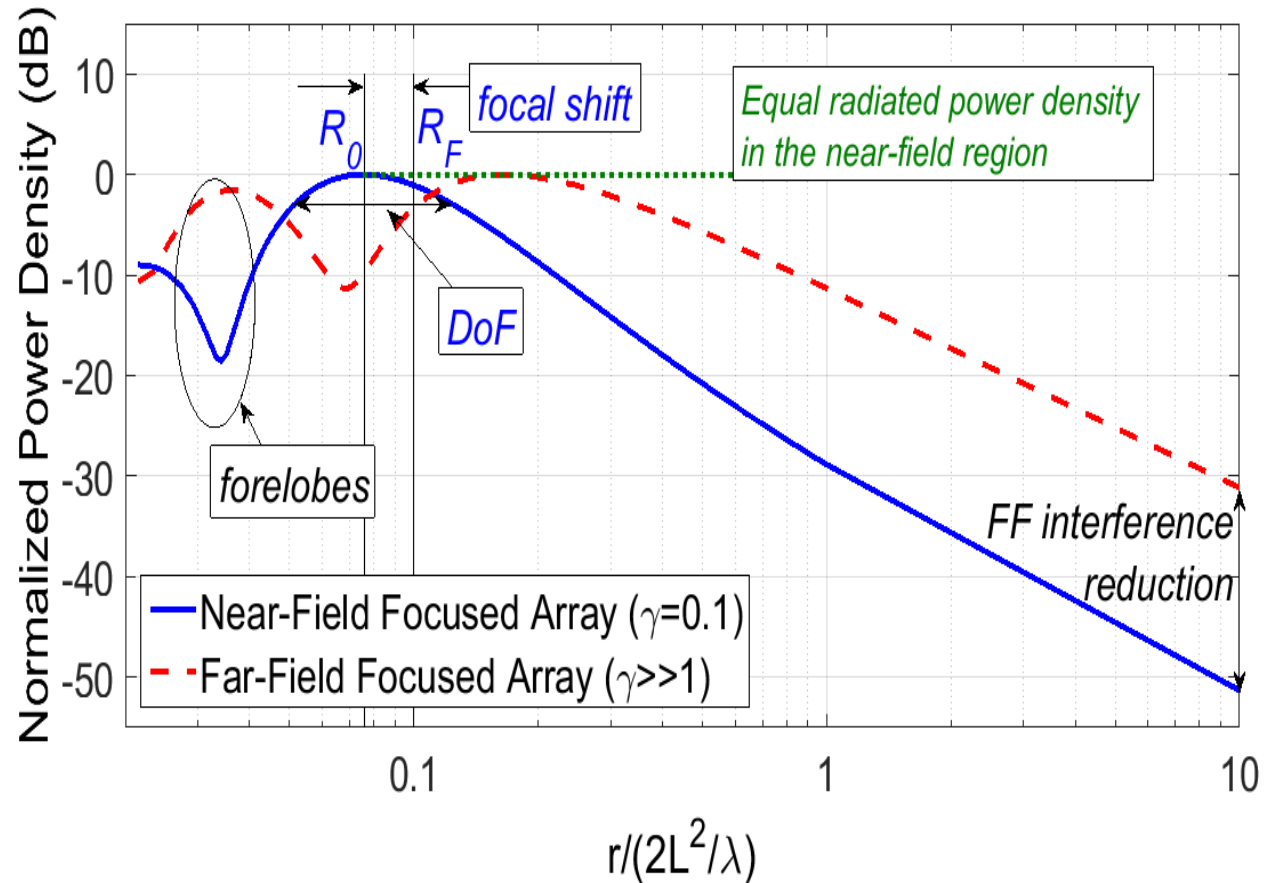
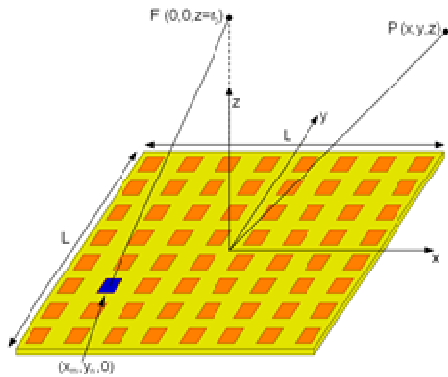

Near-field at the focal plane (xy-plane at $z=R_F$)

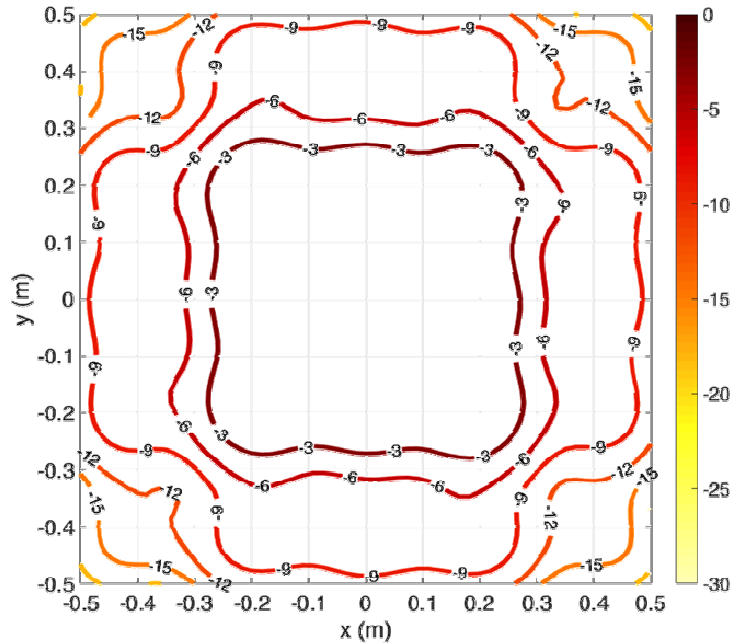

Unfocused 8x8 array
(all patches are fed in phase)

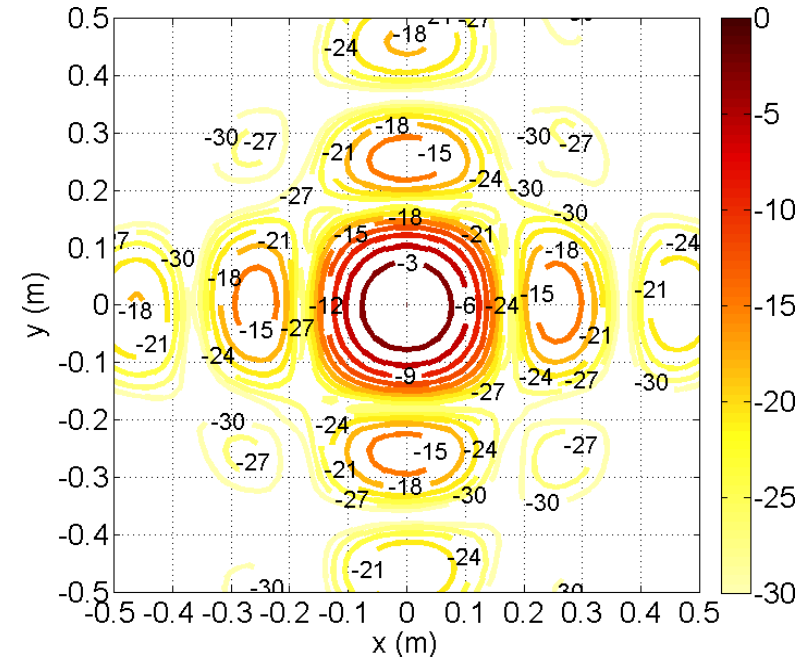

Near-Field **Focused** (NFF) 8x8 array

The **focus width**, W , is defined as the -3 dB spot diameter at the focal plane.

For the NFF 8x8 microstrip array, $W=14.7\text{cm}$ and the sidelobe level in the focal plane is less than -15 dB.

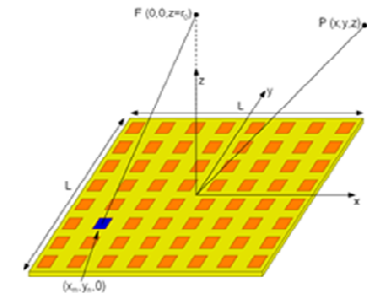

Near-field at the transverse plane

For the NFF 8x8 microstrip array, $W=14.7\text{cm}$, and $\text{DoF}=70.1\text{cm}$

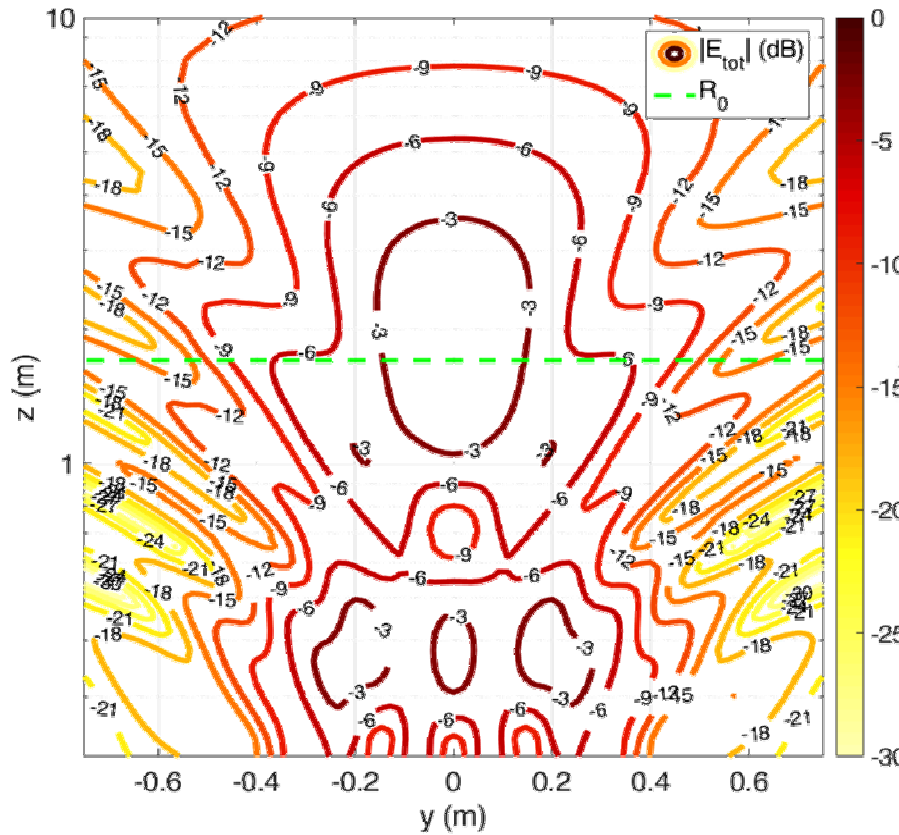

Unfocused 8x8 array
(all patches are fed in phase)

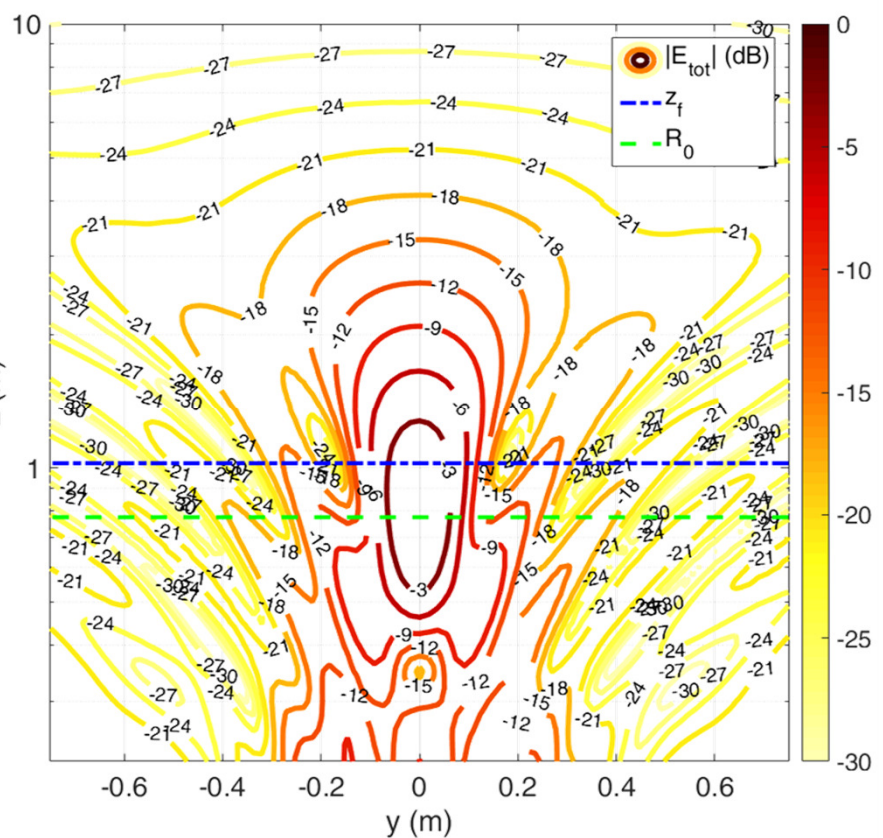

Near-Field Focused (NFF) 8x8 array



Agenda

- ✓ NEAR-FIELD FOCUSED ANTENNAS (NFFAs): CHARACTERISTIC PARAMETERS AND PROPERTIES
- ✓ BASIC DESIGN CRITERIA
- ✓ MICROWAVE NEAR-FIELD APPLICATIONS
- ✓ ADVANCED SYNTHESIS TECHNIQUES
- ✓ TECHNOLOGIES FOR NFF ANTENNAS: EXAMPLES
- ✓ CONCLUSIONS

NFF-array design criteria

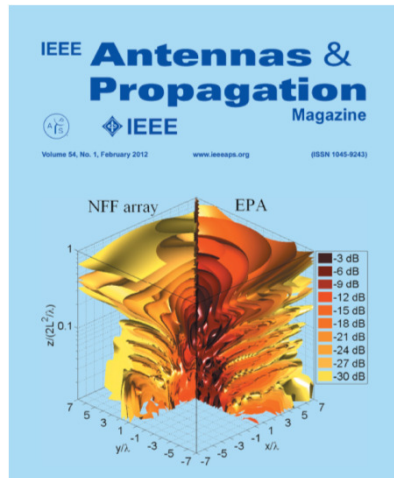

A. Buffi, P. Nepa, and G. Manara,
 "Design Criteria for Near-Field-Focused
 Planar Arrays", *IEEE Antennas and
 Propagation Magazine*, February 2012

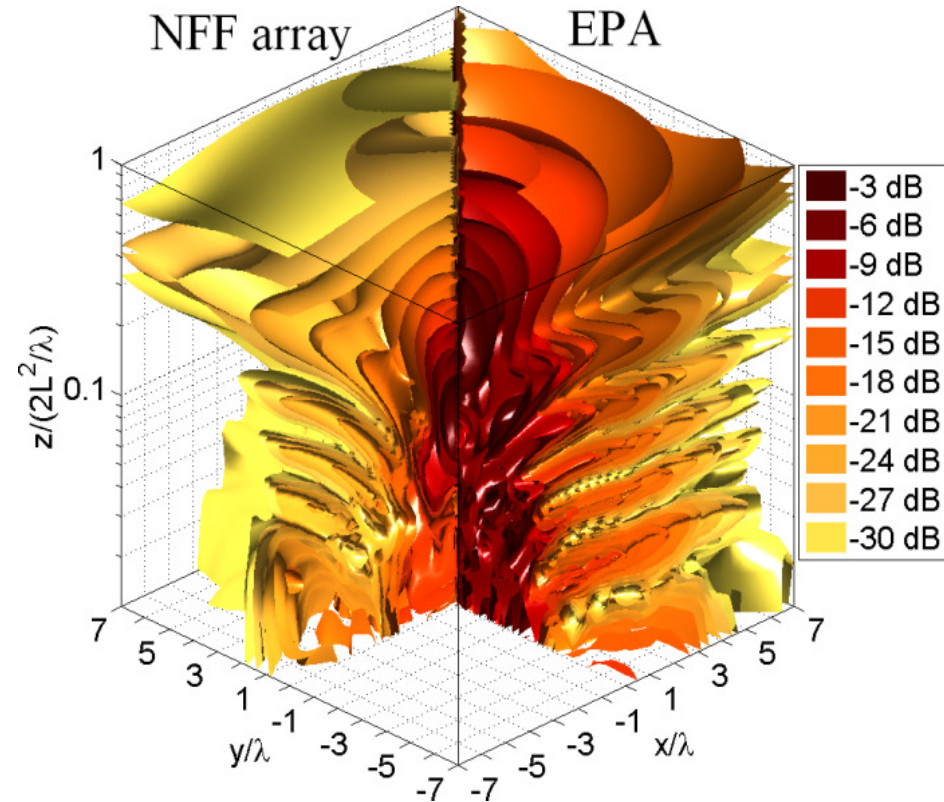

3D view of the normalized power density radiated by a NFF 8x8 array of x -directed short dipoles (inter-element spacing $d=0.8\lambda$, $L=Nd=6.4\lambda$): NFF array with $R_F=8.2\lambda$ (left hand side) and far-field focused array (right hand side)

NFF-array design criteria

NFF antenna parameters mainly depend on:

- the **antenna electrical size**, L/λ
- the **focal distance normalized to the antenna size**, R_F/L , or equivalently $\gamma=R_F/(2L^2/\lambda)$.

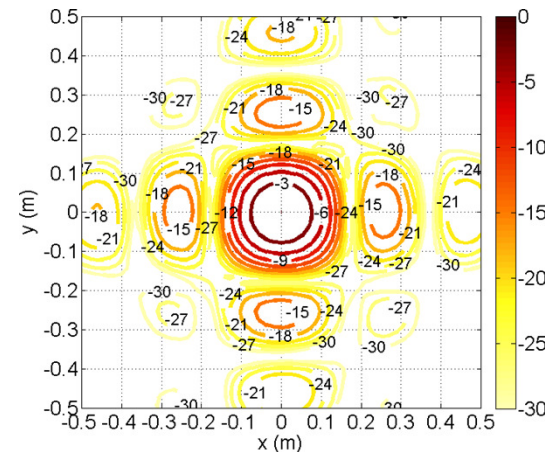
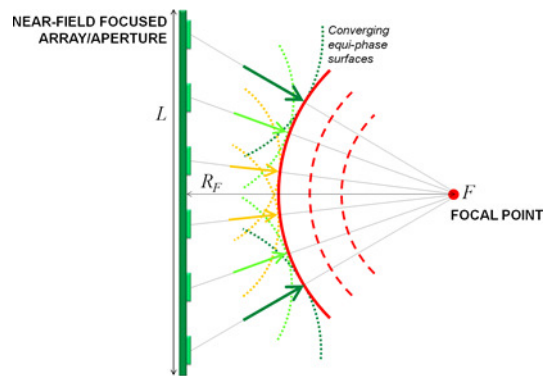

$$W \sim R_F (\lambda/L)$$

For a given NFF antenna, both the focal depth and the focus width increase when the focal point moves far from the array plane.

For a given focal distance, focusing performance improves for larger antennas.

The focal shift vanishes for small values of $\gamma=R_F/(2L^2/\lambda)$

NFF-array design criteria

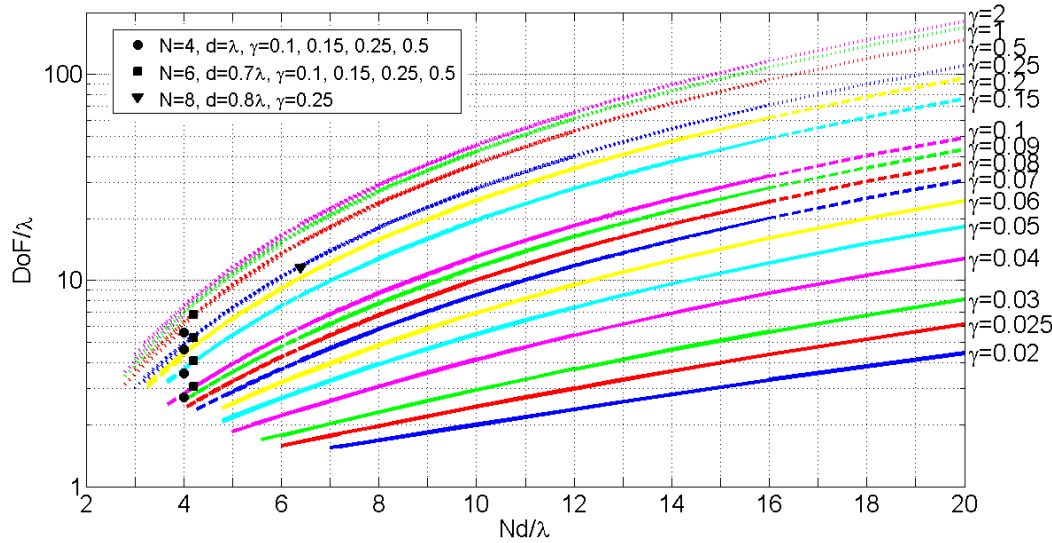

Depth of focus (DoF) as a function of the array size $L/\lambda = Nd/\lambda$, for different values of γ .

$$\gamma = R_F / (2L^2/\lambda)$$

-3 dB spot diameter (spot size in the transverse plane at the focal distance) as a function of the array size $L/\lambda = Nd/\lambda$ for different values of parameter γ : $0.1 < \gamma < 0.25$

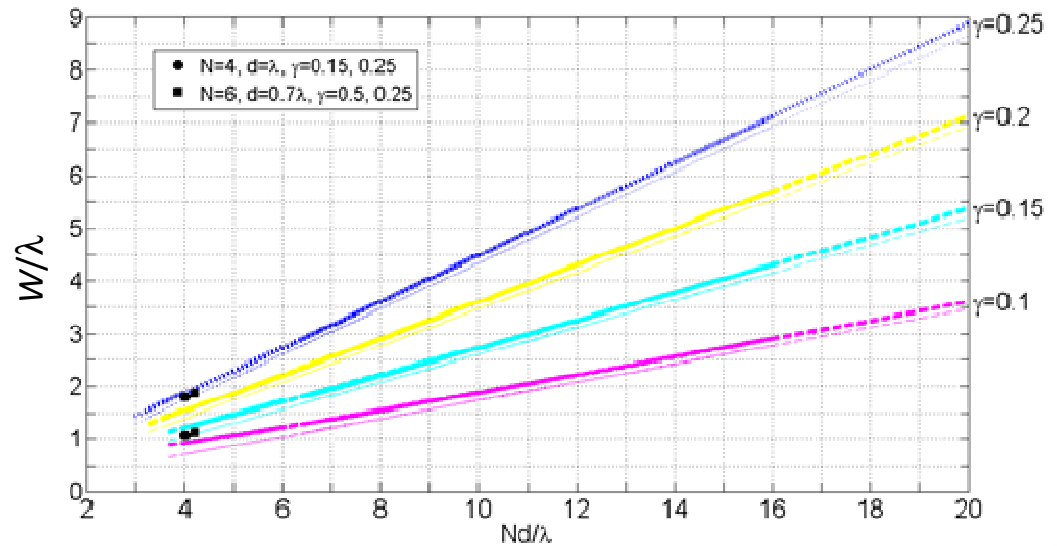

The thick lines represent the numerical data and the thin lines those obtained from an approximate analytical equation. Markers denote performance of NFF microstrip arrays simulated with Ansoft Designer™

A FF-like pattern around the focal point

An 8×8 array of microstrip circularly polarized (CP) patches at 2.4 GHz.
 Inter-element distance $= 0.8\lambda$, $L = 6.4\lambda = 80\text{cm}$, $R_F = 8.2\lambda = 1\text{m}$
 For the NFF array, the normalized focal distance is $\gamma = R_F / (2L^2/\lambda) = 0.1$

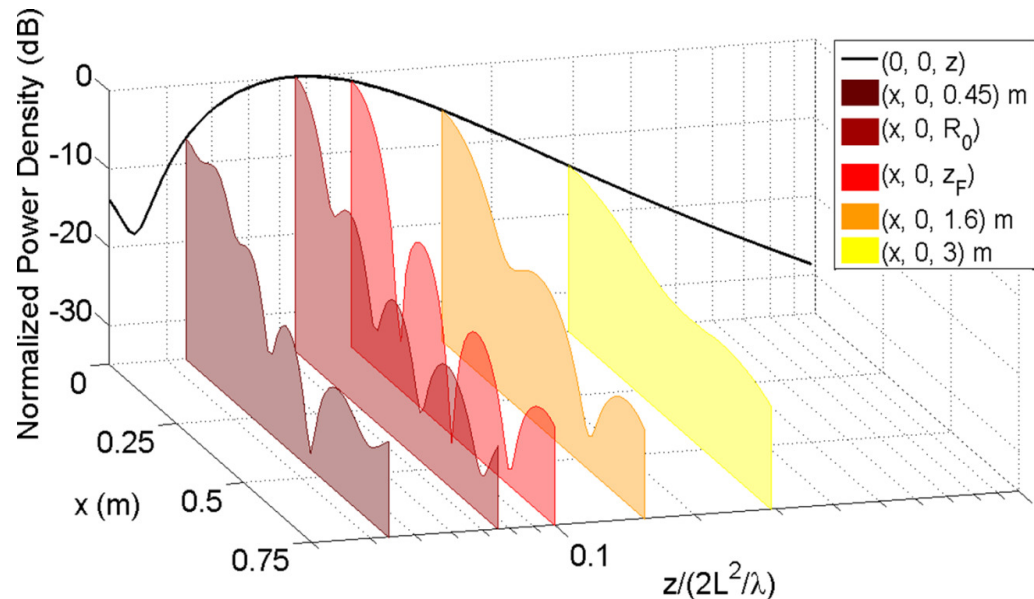

The far-field radiation pattern of a conventional unfocused array can be achieved in the near-field region of the focused antenna

A FF-like pattern around the focal point

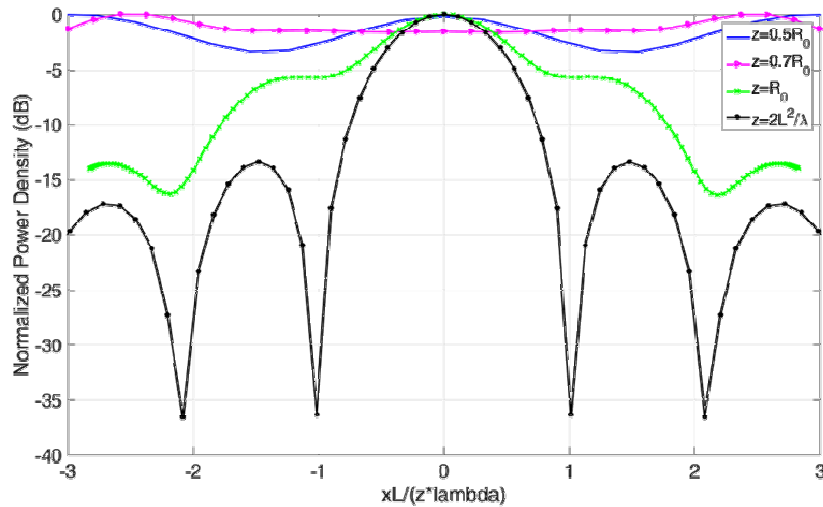
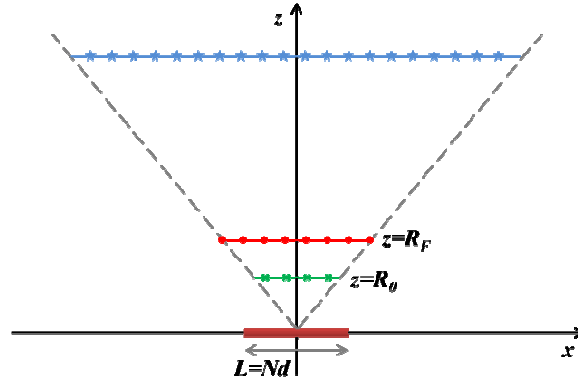

Unfocused 8x8 array (all patches fed in phase)

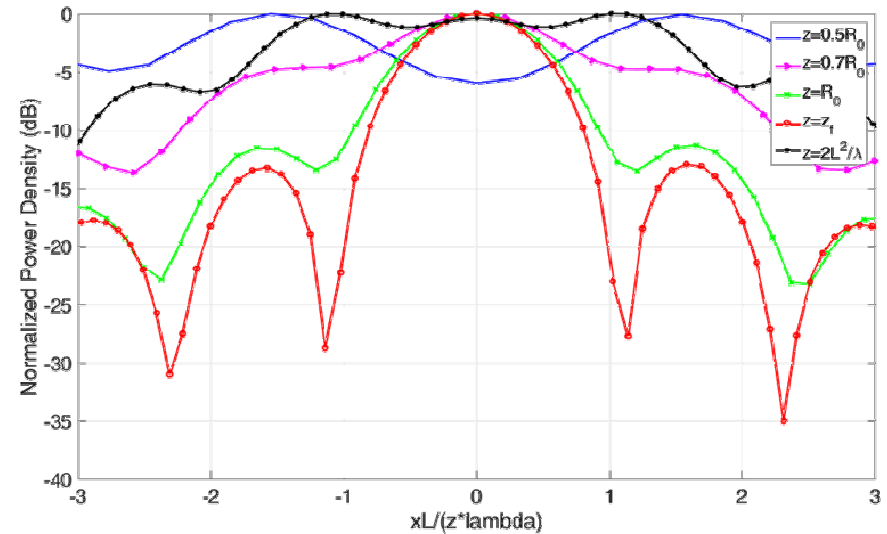

Near-Field **Focused** (NFF) 8x8 array

The conjugate-phase approach

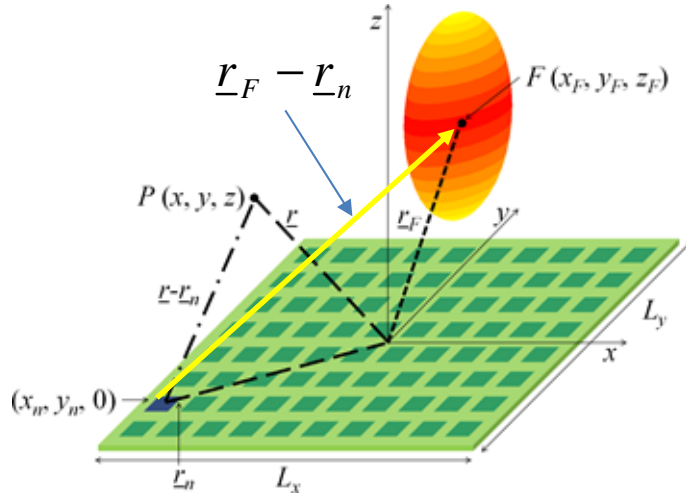

$$\underline{E}(\underline{r}) = \sum_{n=1}^N C_n \underline{E}_n(\underline{r}) = \sum_{n=1}^N C_n \underline{E}_0(\theta_n, \phi_n) \frac{e^{-j2\pi|\underline{r}-\underline{r}_n|/\lambda}}{|\underline{r}-\underline{r}_n|}$$

$$C_n = A_n e^{j\varphi_n}$$

The source phase profile has to compensate for the phase delay introduced by the path between each source point on the antenna/array aperture and the targeted focal point

$$\varphi_n = +\frac{2\pi}{\lambda} |\underline{r}_F - \underline{r}_n| = \frac{2\pi}{\lambda} \sqrt{(x_F - x_n)^2 + (y_F - y_n)^2 + z_F^2} = \frac{2\pi}{\lambda} \sqrt{R_F^2 + |\underline{r}_n|^2 - 2R_F \hat{r}_F \cdot \underline{r}_n}$$

The electric field at the generic observation point \underline{r} :

$$\underline{E}(\underline{r}) = \sum_{n=1}^N A_n \underline{E}_0(\theta_n, \phi_n) \frac{e^{-j2\pi(|\underline{r}-\underline{r}_n| - |\underline{r}_F - \underline{r}_n|)/\lambda}}{|\underline{r}-\underline{r}_n|}$$

At the focal point, all contributions sum in phase:

$$\underline{E}(\underline{r} = \underline{r}_F) = \sum_{n=1}^N A_n \underline{E}_0(\theta_n, \phi_n) / |\underline{r}_F - \underline{r}_n|$$

The quadratic phase approx.

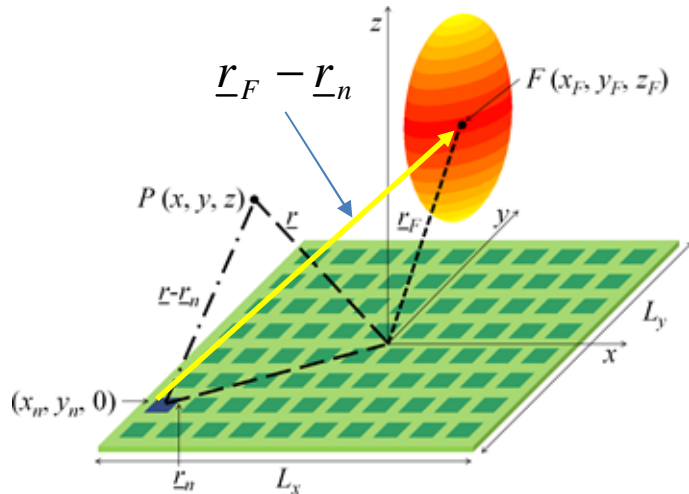

If the focal distance is enough larger than the antenna size ($R_F > L$), the phase tapering required for focusing at the focal point can be approximated by the sum of a linear phase shift plus a quadratic term (Fresnel approximation)

$$\varphi_n \approx -\frac{2\pi}{\lambda} (\hat{r}_F \cdot \underline{r}_n) + \frac{2\pi}{\lambda} \frac{|\underline{r}_n|^2}{2R_F}$$

The linear phase shift (first term at the right hand side) corresponds to the phase excitation required to point at the focal point direction (θ_F, ϕ_F) when the focal point is beyond the FF-region boundary (parallel ray approximation).

The focal shift

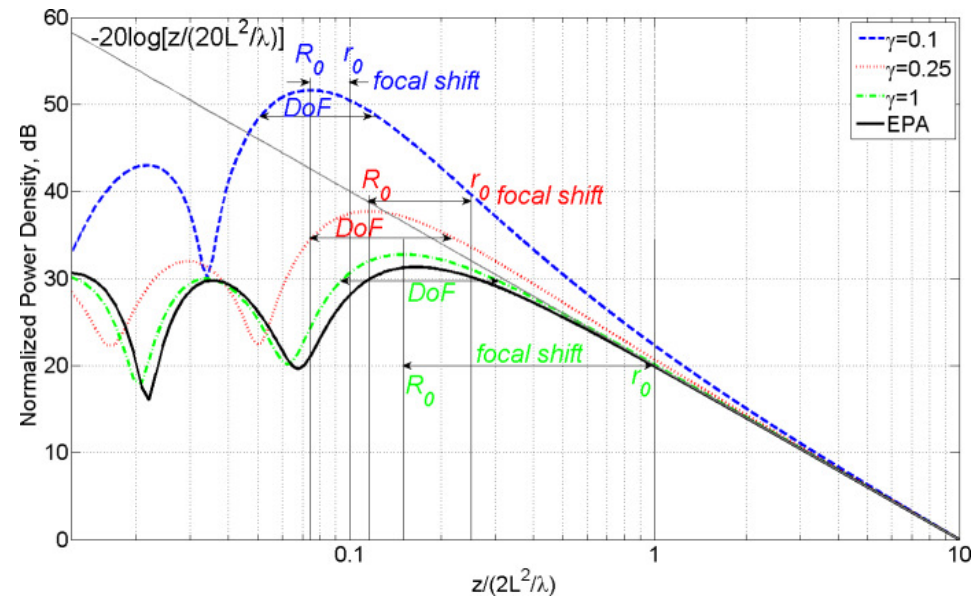

$$\gamma = R_F / (2L^2 / \lambda)$$

$$\underline{E}(\underline{r}) = \sum_{n=1}^N A_n \underline{E}_0(\theta_n, \phi_n) \frac{e^{-j2\pi(|\underline{r}-\underline{r}_n| - |\underline{r}_F - \underline{r}_n|) / \lambda}}{|\underline{r} - \underline{r}_n|}$$

When moving from the focal point toward the antenna aperture, array contributions does not sum in phase anymore; on the other hand, the expected amplitude reduction is over-compensated by the fact that each element contribution exhibits a higher amplitude close to the antenna aperture, as the spreading factor $1/|\underline{r} - \underline{r}_n|$ increases.

Equi-phase surfaces

Near-field phase around the focal point: a quasi-planar equiphase surface is achieved while passing from concave to convex equiphase surfaces.

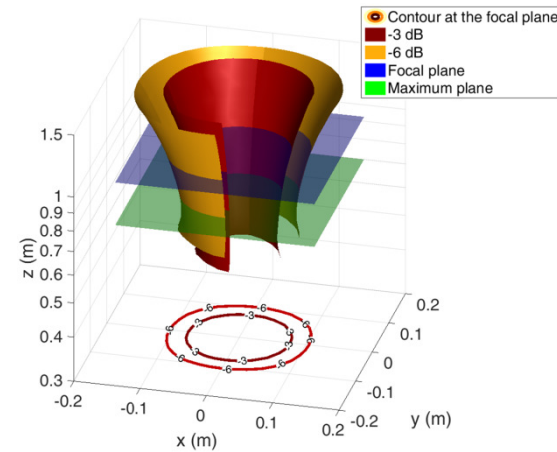
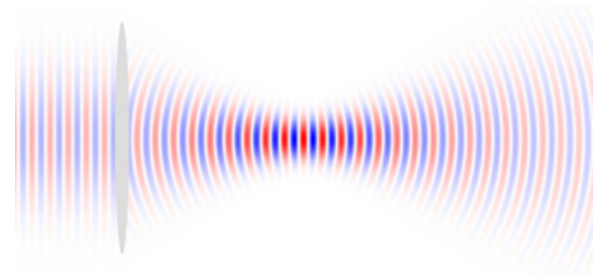
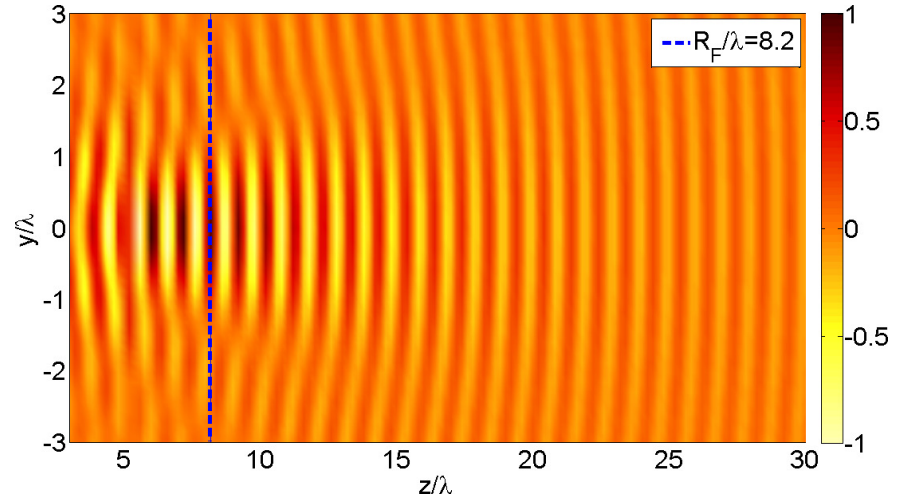
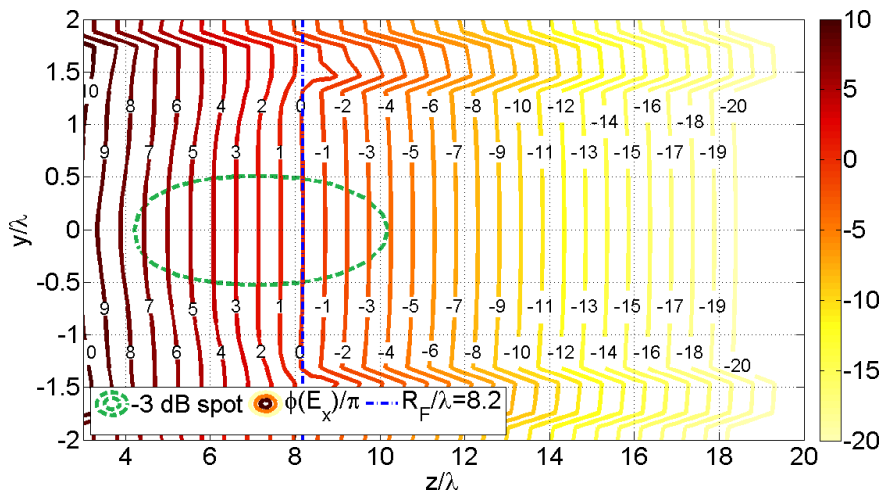



Agenda

- ✓ NEAR-FIELD FOCUSED ANTENNAS (NFFAs): CHARACTERISTIC PARAMETERS AND PROPERTIES
- ✓ BASIC DESIGN CRITERIA
- ✓ MICROWAVE NEAR-FIELD APPLICATIONS
- ✓ ADVANCED SYNTHESIS TECHNIQUES
- ✓ TECHNOLOGIES FOR NFF ANTENNAS: EXAMPLES
- ✓ CONCLUSIONS



Radio Frequency Identification Systems

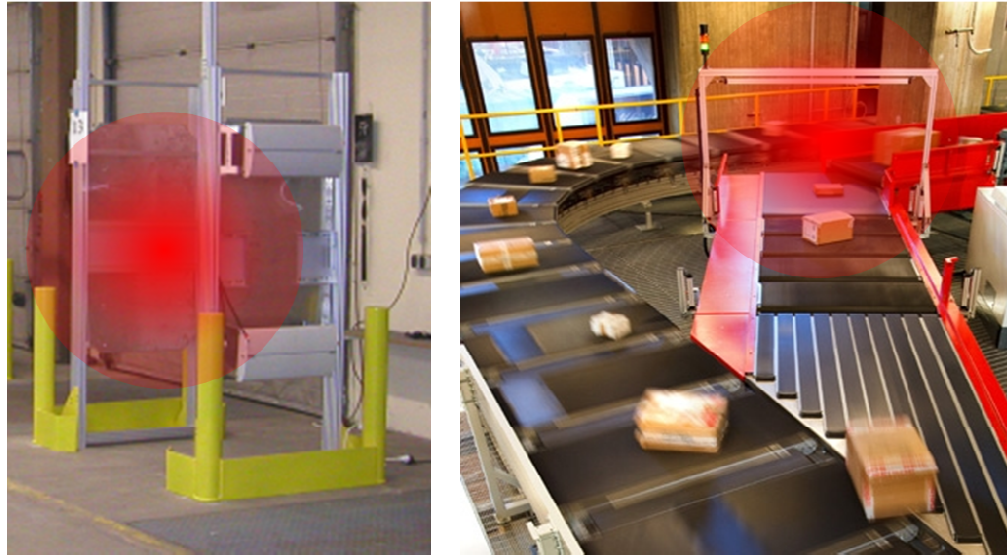

Field focusing in UHF-RFID reader antennas can help to both reduce the interference between adjacent RFID portals in large warehouses and limit the reader interrogation volume at a specific section of a conveyor belt along which the tagged items move.

A NFF antenna can limit the false positive readings (cross readings), as well as the personnel radiation hazards.

By reducing FF-radiation the multipath phenomena will be attenuated.

Radio Frequency Identification Systems

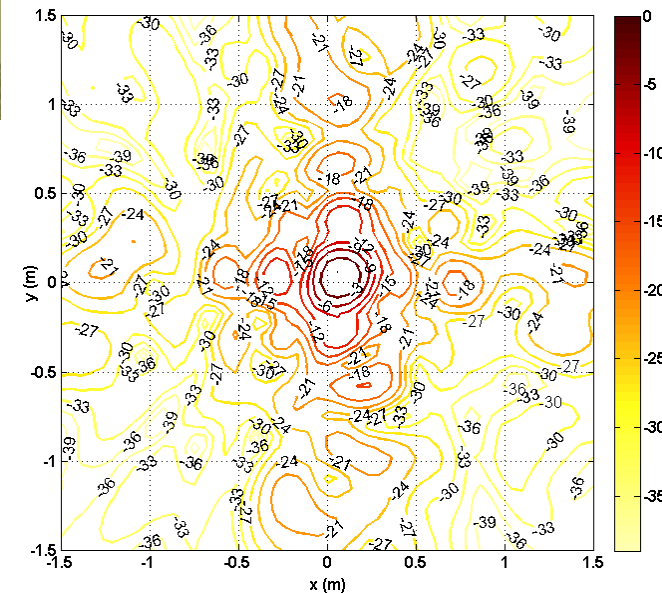
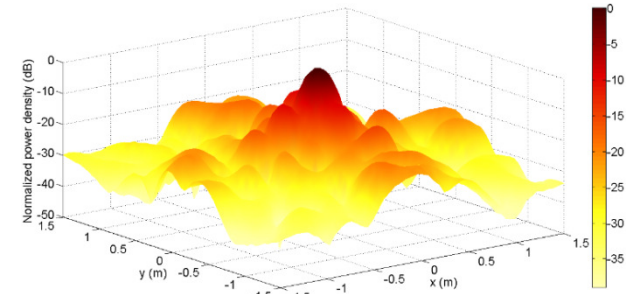
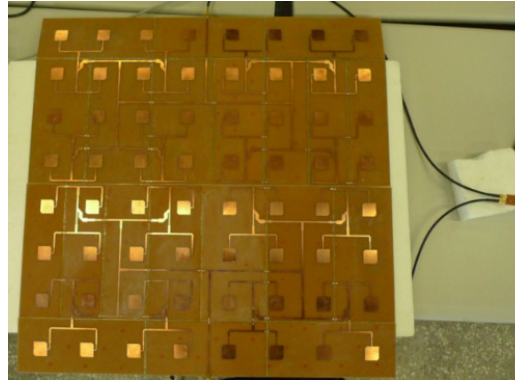
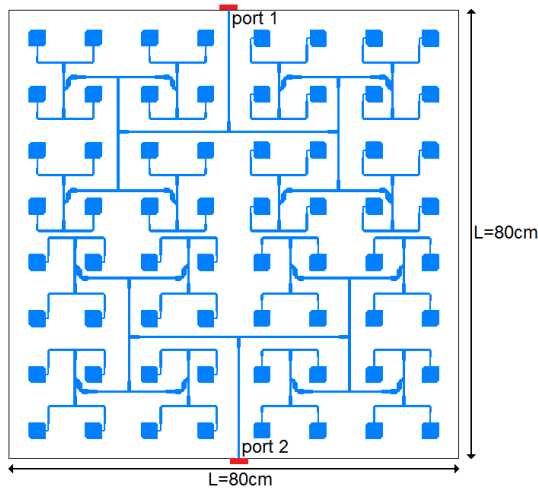

An 8x8 array of CP patches (interelement distance equal to 0.8λ)
 Array size: 80cmx80cm ($6.4\lambda \times 6.4\lambda$ at 2.4GHz)

Maximum field position at 1.5m from the array surface (nominal focal distance= 2.7m)

-3dB focal width: 20cm at 1.5m from the array surface

Depth of Focus= 1.4m

Measured normalized power density in a 3mx3m square area at a distance of 1.5m (focal distance) from the surface of the array prototype

A. Buffi, A. A. Serra, P. Nepa, H. T. Chou, and G. Manara, "A Focused Planar Microstrip Array for 2.4 GHz RFID Readers", *IEEE Transactions on Antennas and Propagation*, March 2010

Industrial Microwave Applications

In **non-contact non-destructive microwave material inspections**, a focused field is effective to increase the sensor sensitivity when either measuring small spatial variations of the material characteristics in large samples or testing small material samples (as for example, when measuring variations of moisture content during a drying process).

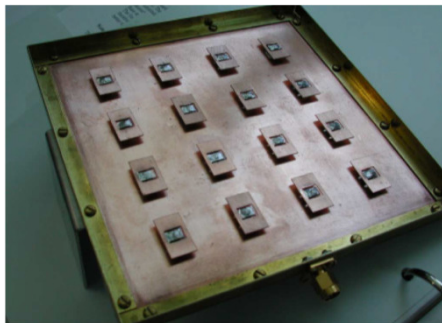
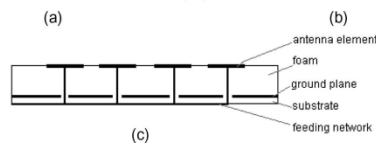
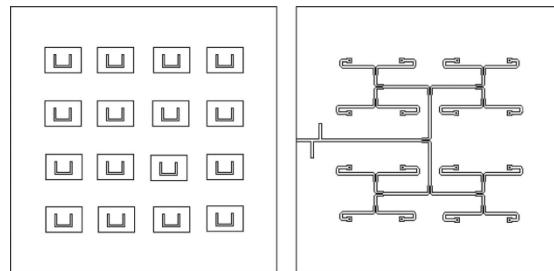

A 4x4 array (15cmx15cm) of LP coaxial-fed U-slotted patches (10-12 GHz)
 -3dB focal width: 3cm (focal length=12.6cm) and 7.6cm (focal length=30cm)

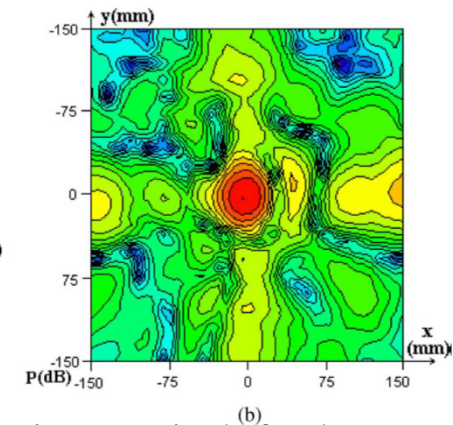
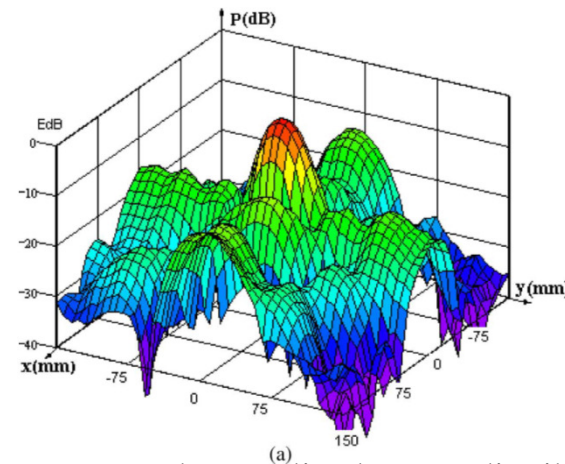

Measured normalized power distribution magnitude for the 4x4 array with 12.6cm focal length

M. Bogosanović and A. G. Williamson, "Microstrip Antenna Array with a Beam Focused in the Near-Field Zone for Application in Noncontact Microwave Industrial Inspection", *IEEE Transactions on Instrumentation and Measurements*, December 2007



Industrial Microwave Applications

NFF arrays can also be used for **temperature sensing by microwave radiometry (12.5GHz)**.

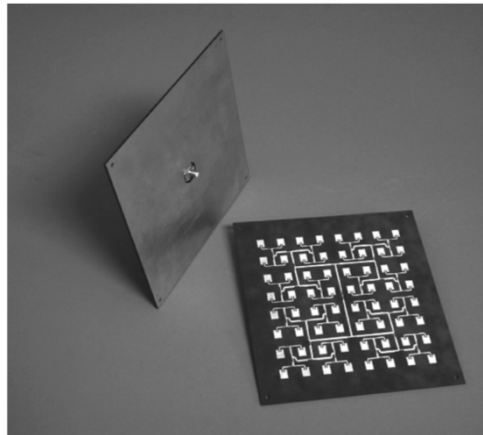
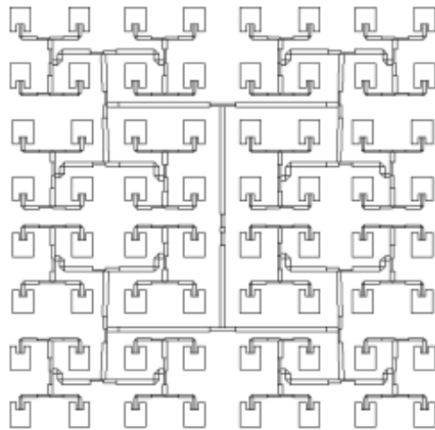

An 8x8 array (18.5cmx18.5cm; $6.4\lambda \times 6.4\lambda$ at 12.5GHz) made of sixteen subarrays.

Each subarray is a 2x2 array of LP inset-fed patches.

The -6dB spot width is 6.6cm at 30cm from the array surface.

A 20dB-Taylor amplitude tapering is used to reduce the sidelobe level.

K. D. Stephan, J. B. Mead, D. M. Pozar, L. Wang, and J. A. Pearce, "A Near Field Focused Microstrip Array for a Radiometric Temperature Sensor", *IEEE Transactions on Antennas and Propagation*, April 2007

Other applications are about industrial microwave heating, subsurface probing, concealed weapon detection, foreign object detection inside lossy media, plasma heating, non-lethal microwave weapons, short-range high-data-rate point-to-point communications.

Further Applications

In biomedical engineering, to improve spatial resolution in imaging systems or to increase the temperature in size-limited spot regions.

In microwave hyperthermia applicators, the deposited power density must be maximized in a limited spot area around the diseased tissue, without overheating the surrounding healthy tissues.

Communication/tracking systems for wireless endoscopic capsules or in antennas for remote monitoring of vital signs.

In non-radiating wireless power transfer systems, both the receiving and transmitting antennas are required to have a size comparable to the operating distance. Then, in those applications where the above distance cannot be sufficiently small, a radiating coupling is a mandatory solution, and a NFF antenna can increase the power transfer efficiency at the receiving antenna when compared to a conventional FF-focused antenna.

Multi-focus NFF antennas could also be applied in multi-point wireless power charging systems for mobile electronic devices, or in smart antennas for simultaneous wireless information and power transfer.

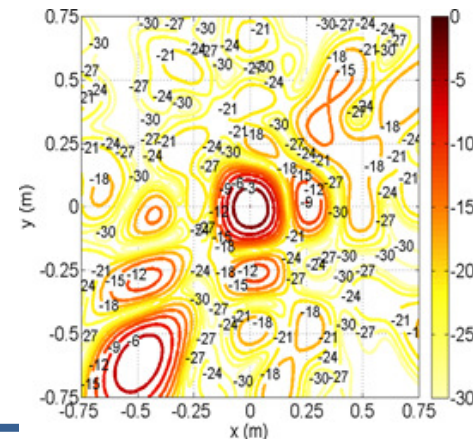

$$F_1(0, 0, 8.2\lambda)$$

$$F_2(-4\lambda, -5\lambda, 8.2\lambda)$$

Further Applications

NF-focusing of large phased arrays has been proposed for performing **adaptive array nulling tests** by conveniently resorting to interference sources located in the antenna NF-region instead of interference sources located in the far field of the unfocused phased array.

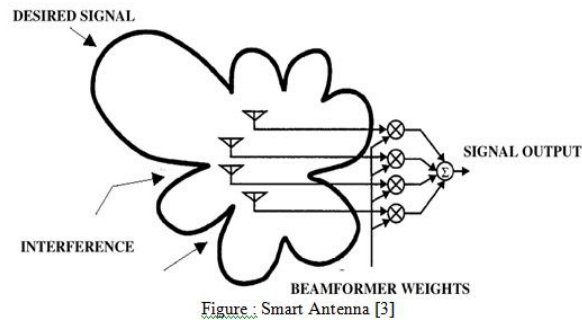

Plane-wave generators used for antenna testing and radar cross section measurements in compact anechoic chambers belong to the class of NFF antennas exhibiting a specific near-field shaping, namely, a local plane wave field in the targeted quiet zone

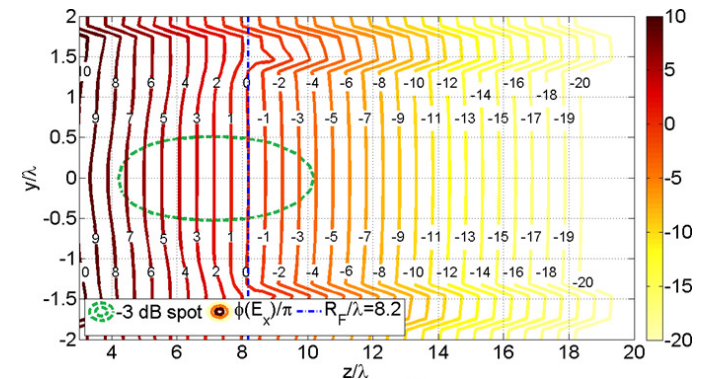
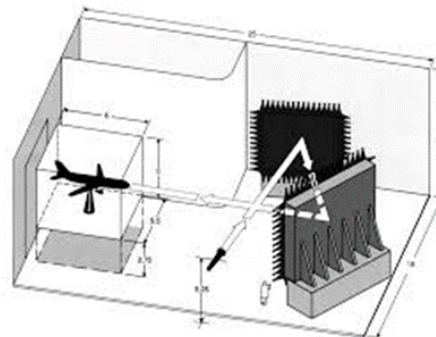
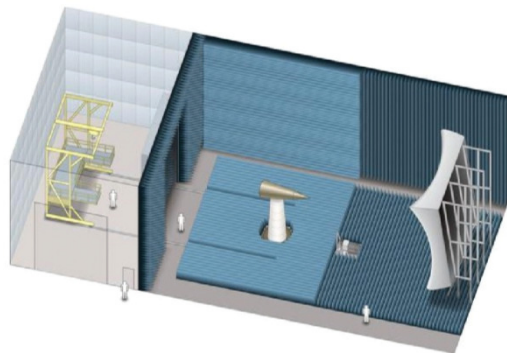



Agenda

- ✓ NEAR-FIELD FOCUSED ANTENNAS (NFFAs): CHARACTERISTIC PARAMETERS AND PROPERTIES
- ✓ BASIC DESIGN CRITERIA
- ✓ MICROWAVE NEAR-FIELD APPLICATIONS
- ✓ **ADVANCED SYNTHESIS TECHNIQUES**
- ✓ TECHNOLOGIES FOR NFF ANTENNAS: EXAMPLES
- ✓ CONCLUSIONS



Advanced Design Criteria

$$\varphi_n = +\frac{2\pi}{\lambda} |\underline{r}_F - \underline{r}_n| = \frac{2\pi}{\lambda} \sqrt{(x_F - x_n)^2 + (y_F - y_n)^2 + z_F^2} = \frac{2\pi}{\lambda} \sqrt{R_F^2 + |\underline{r}_n|^2 - 2R_F \hat{r}_F \cdot \underline{r}_n},$$

In the **conjugate-phase approach**, the phase of the excitation of each antenna radiation source is set to compensate for the phase delay introduced by the path between the source and the assigned focal point.

A proper tapering of the amplitude of the excitation can be chosen to control the level of the secondary lobes around the focal spot region.

Excitation tapering

Synthesis of the amplitude of the array excitation (excitation tapering) to control the level of the lateral lobes around the focal spot.

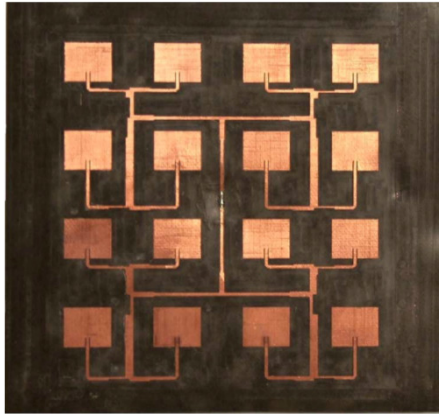

$f=10\text{GHz}$
 4x4 patch array (8cmx8cm)
 Dolph-Chebyshev amplitude tapering plus a quadratic phase profile
 Maximum field amplitude at 6.2cm from the array surface (targeted focal point at 20cm)

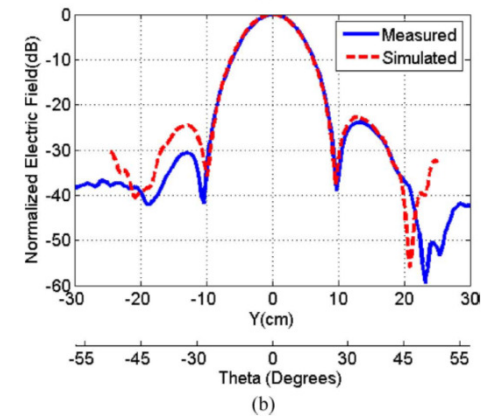
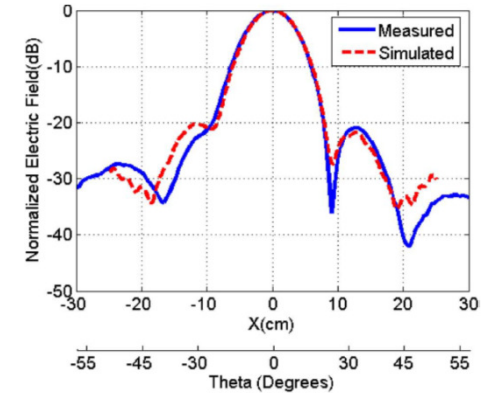
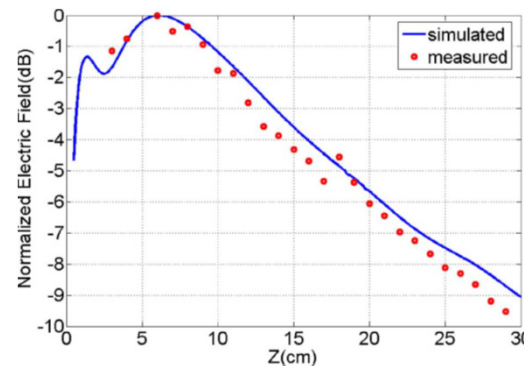
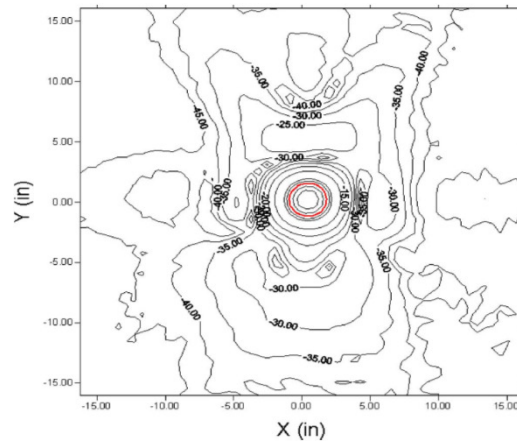

Normalized electric field distributions along perpendicular directions onto the focal plane: (a) E-plane and (b) H-plane

S. Karimkashi and A. A. Kishk, "Focused Microstrip Array Antenna Using a Dolph-Chebyshev Near-Field Design", *IEEE Transactions on Antennas and Propagation*, December 2009



..... beyond the conjugate-phase method

Multi-objective optimization techniques: both the amplitude and phase of the source excitations are simultaneously determined through *ad-hoc* optimization techniques.

They are much more general and flexible, in that they allow to concurrently optimize many NFF antenna parameters, for almost arbitrary antenna configurations and complex application scenarios.

They can be applied to the synthesis of:

NFF arrays with unequal elements, NFF antennas radiating in lossy and/or non-homogeneous media, antennas radiating in presence of scatterers in their NF region, NF/NF or NF/FF multi-focus antennas, plane-wave generators.

Multi-focus antennas

Synthesis techniques for multi-focus antennas

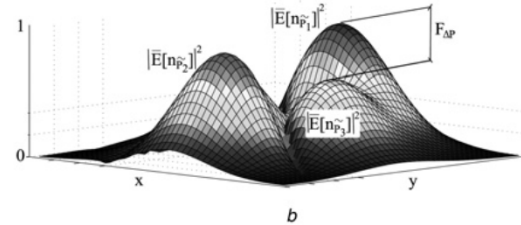
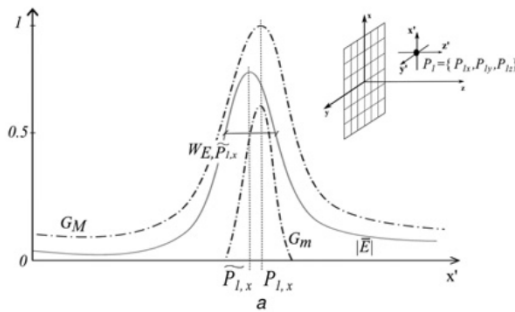

J. Álvarez, R. G. Ayestarán, G. León, L. F. Herrán, A. Arboleya, J. A. López-Fernández, and F. Las-Heras, “Near field multifocusing on antenna arrays via non-convex optimisation”, *IET Microwaves, Antennas & Propagation*, 2014

Optimization framework based on the iterative Levenberg-Marquardt algorithm to minimize a cost function related to the required shape of the near-field amplitude around each focal point. Amplitude and phase of the array excitations are the unknowns (phase-only synthesis can be used).

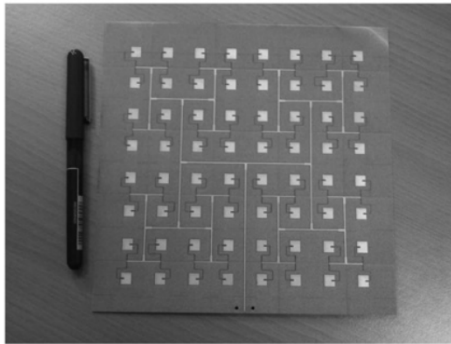

$f=12\text{GHz}$, an 8×8 array of inset-fed patches
Two focal points (at 12cm and 16cm from the array surface, out of the array axis)

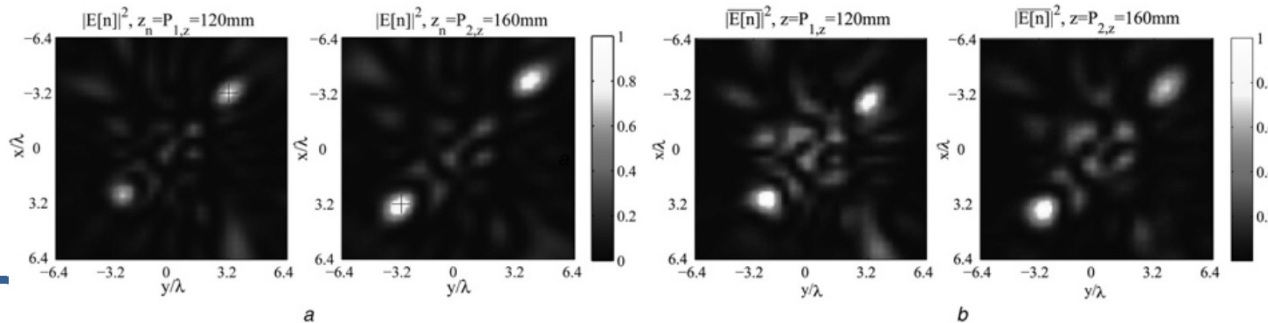

- (a) Simulated results (phase-only synthesis)
- (b) Prototype measurements

Power Transfer Efficiency Optimization

Synthesis techniques accounting for the presence of obstacles and non-uniform materials between the NFFA and the focal point, as well as for the mutual-coupling effects among the array elements.

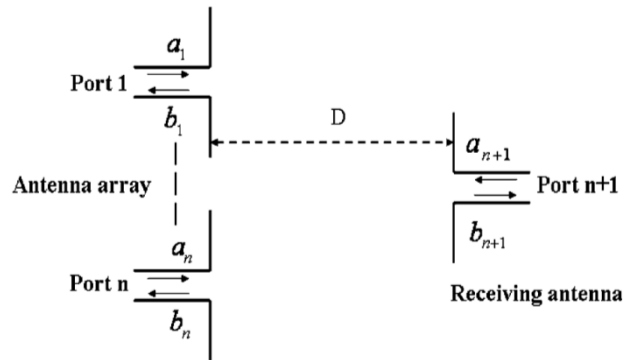

Eigenvalue problem obtained by imposing the maximization of the power transfer efficiency between an N -element array and a receiving antenna (for any distance between the two antennas). Its solution gives the array excitation coefficients.

A 6×6 array at 2.45GHz. Interelement distance = 7cm, focal distance equal to 20cm. Maximum power transfer efficiency: 27.7%.

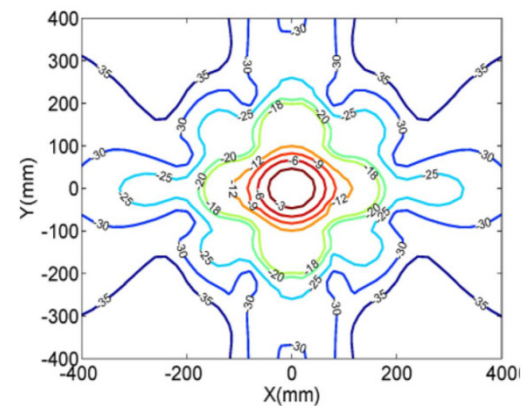

Contour plot of simulated normalized electric field at the maximum field intensity plane (15cm from the array surface)

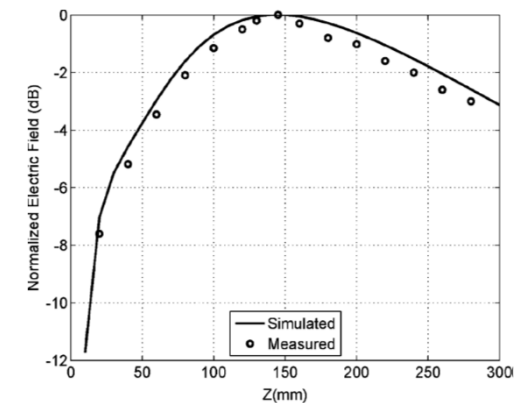
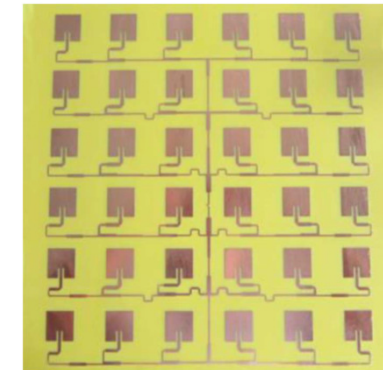

L. Shan and W. Geyi, "Optimal Design of Focused Antenna Arrays", *IEEE Transactions on Antennas and Propagation*, November 2014

Circular arrays for focus scan

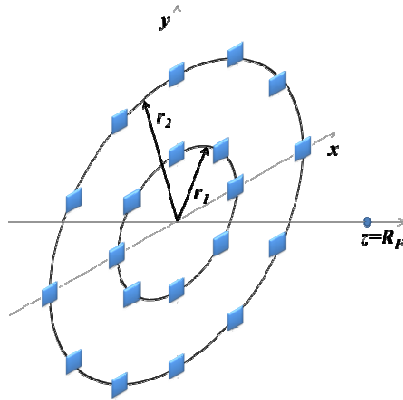

Only one phase shifter for each array ring is required, as all the array elements on the same ring are equidistant from the focal point. Therefore $N-1$ phase shifters are needed for a circular array made of N rings.

The array is made of three circular rows of radii 10, 30, and 50 cm; eight printed dipoles per row.
Working frequency: 5.8 GHz
Panel size: 1.1mx1.1m

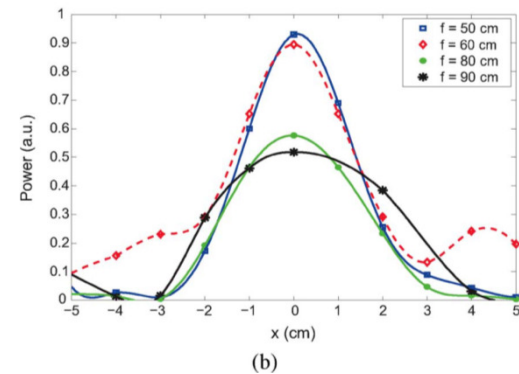
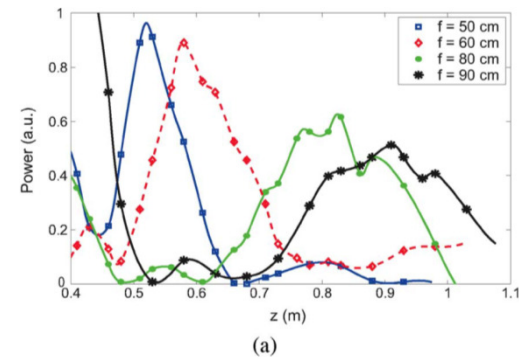
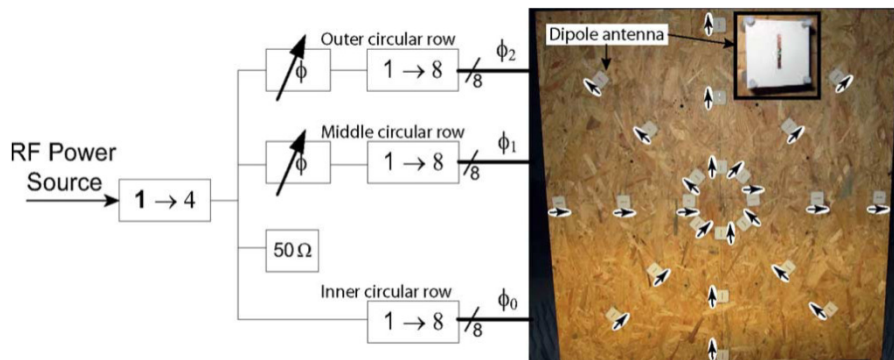

R. Siragusa, P. Lemaître-Auger, and S. Tedjini, “Tunable near-field focused circular phase-array antenna for 5.8-GHz RFID applications”, *IEEE Antennas and Wireless Propagation Letters*, 2011

Field polarization at the focal point

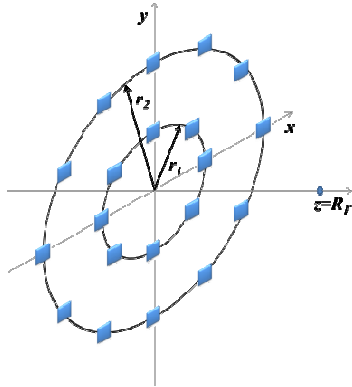

A 4 dB improvement in terms of field amplitude increase at the focal spot region has been obtained by using a collinear orientation of the dipoles instead of the radial orientation

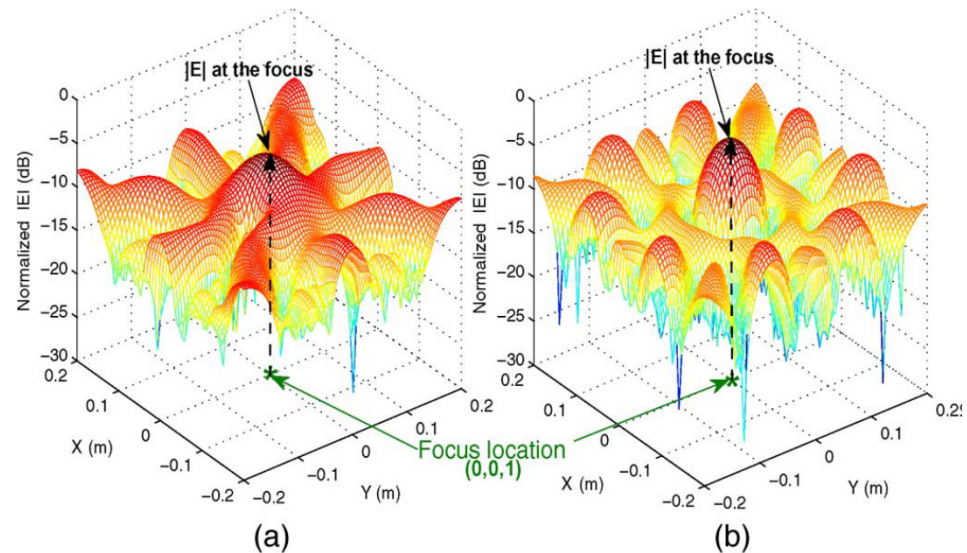
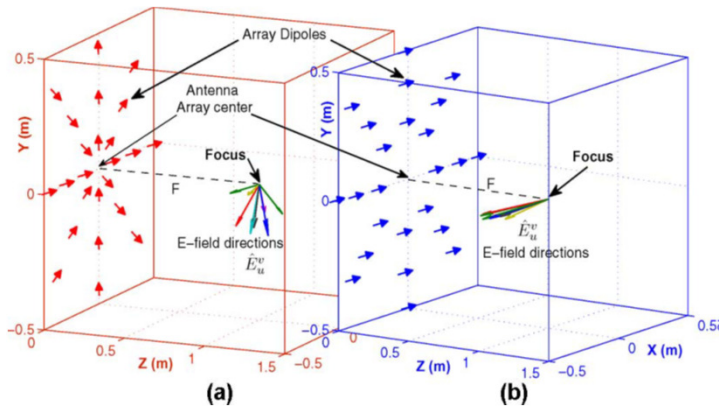

(a) Radially oriented dipoles – ring radii: 10cm, 30cm, 50cm; (b) collinearly oriented dipoles – ring radii: 22cm, 37cm, 50cm.
(Focal point at 1m from the array surface)

A. Sharma, I. J. Garcia Zuazola, R. Martinez, J. C. Batchelor, A. Perallos, and L. de-Haro Ariet, “Optimal E-Field Vector Combination of a Highly Focused Antenna-Array”, *IEEE Antennas and Wireless Propagation Letters*, 2014



Agenda

- ✓ NEAR-FIELD FOCUSED ANTENNAS (NFFAs): CHARACTERISTIC PARAMETERS AND PROPERTIES
- ✓ BASIC DESIGN CRITERIA
- ✓ MICROWAVE NEAR-FIELD APPLICATIONS
- ✓ ADVANCED SYNTHESIS TECHNIQUES
- ✓ TECHNOLOGIES FOR NFF ANTENNAS: EXAMPLES
- ✓ CONCLUSIONS

Near-field focused reflectarray

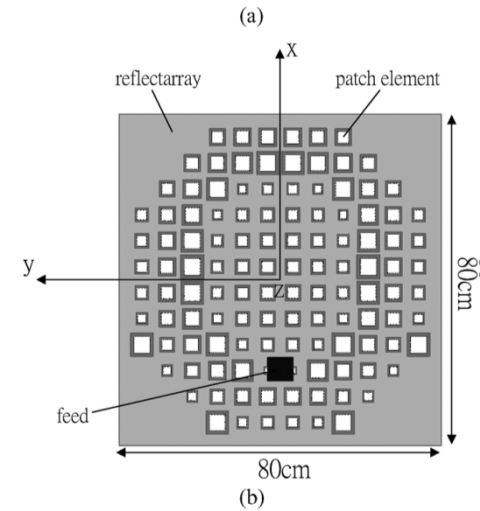
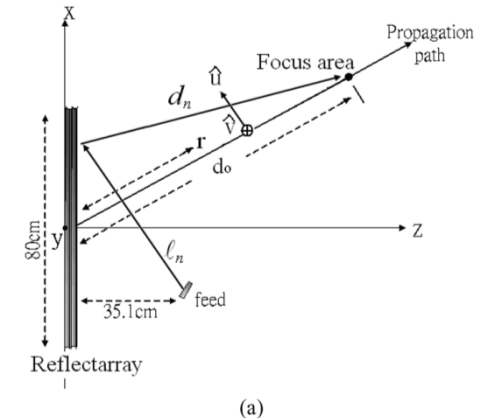
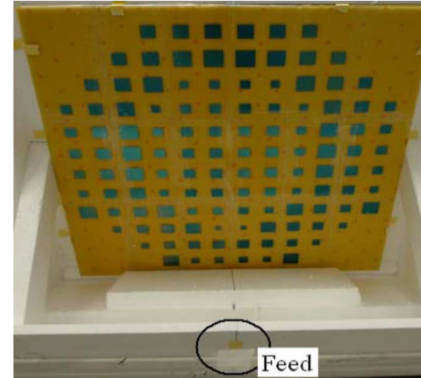
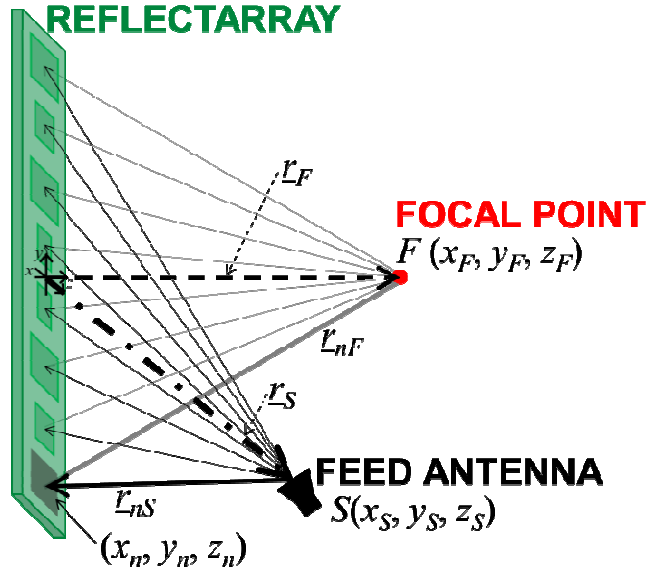

φ_n : phase delay to be introduced by the n -th array element

$$\varphi_n = 2\pi / \lambda \left[(r_{nS} + r_{nF}) - (r_S + r_F) \right]$$

$f=2.4\text{GHz}$

Focal width $W=7.8\text{cm}$ at a plane at 90cm from the reflectarray center

H.-T. Chou, T.-M. Hung, N.-N. Wang, H.-H. Chou, C. Tung, and P. Nepa, "Design of a near-field focused reflectarray antenna for 2.4 GHz RFID reader applications", *IEEE Transactions on Antennas and Propagation*, 2011

Near-field focused transmitarray

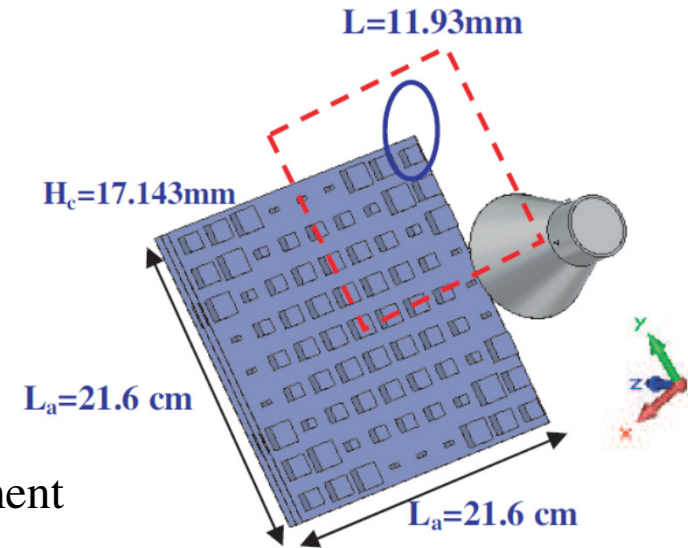
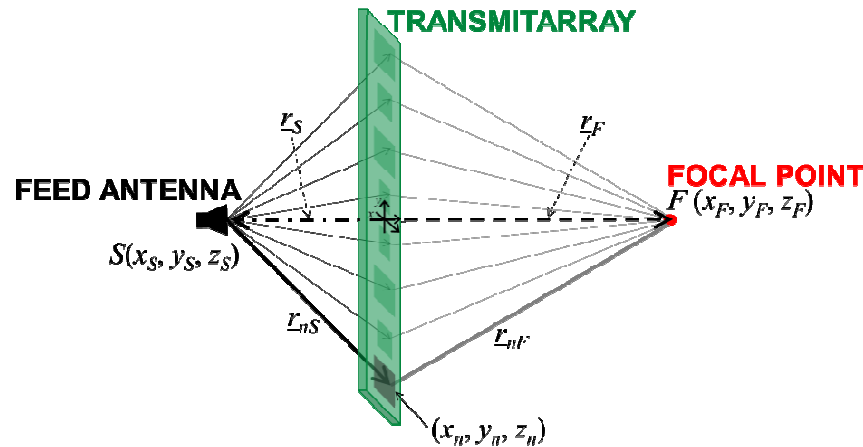

φ_n : phase delay to be introduced by the n -th array element

$$\varphi_n = 2\pi / \lambda \left[(r_{nS} + r_{nF}) - (r_S + r_F) \right]$$

A 9x9 array of CP square dielectric resonator antennas (the side length is used for tuning)

Feed horn at 28.4cm from the array

Focal plane at 40cm from the array

$f=5.8\text{GHz}$

Focal width $W=7.8\text{cm}$

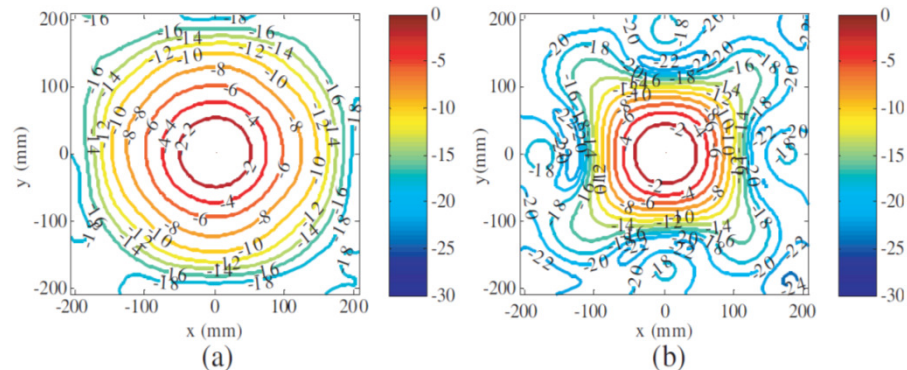

(a) far-field focused, (b) near-field focused

S. H. Zainud-Deen, S. M. Gaber, H. A. Malhat, and K. H. Awadalla, "Multilayer dielectric resonator antenna transmitarray for near-field and far-field fixed RFID reader", *Progress In Electromagnetics Research C*, 2012

NFF Fresnel Zone Plate Lens (FZPL)

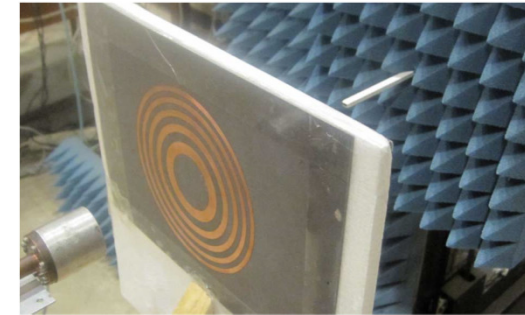
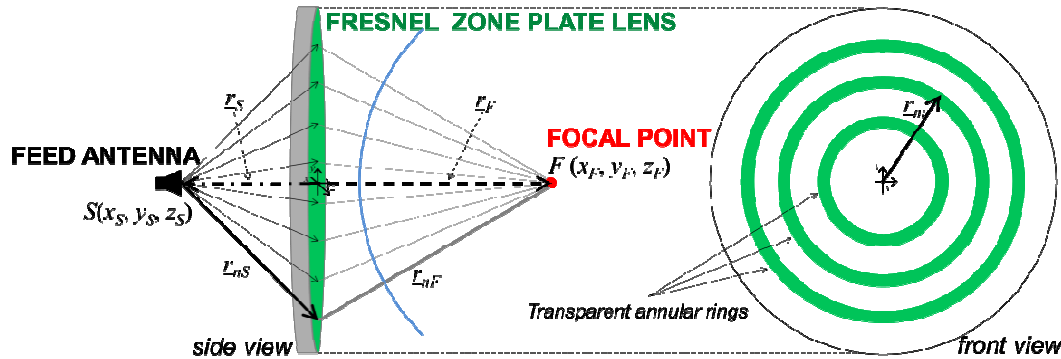

$$\left(\sqrt{r_m^2 + r_s^2} - r_s\right) + \left(\sqrt{r_m^2 + r_f^2} - r_f\right) = m\lambda / 2$$

Ka band (32GHz)

Circular plate diameter = 16cm

Feed horn at 9.5cm from the lens surface

Focus width: 1.24cm (focal length=15cm) and 3.4cm (focal length=45cm)

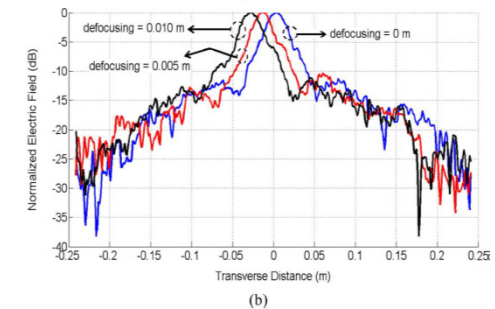
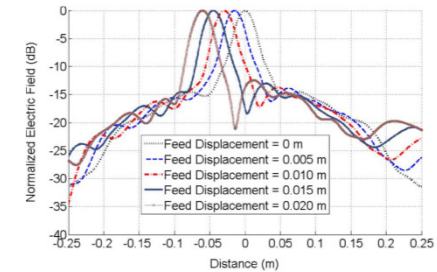
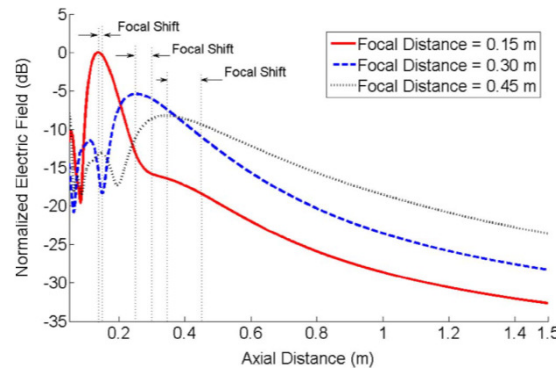

S. Karimkashi and A. A. Kishk, "Focusing Properties of Fresnel Zone Plate Lens Antennas in the Near-Field Region," *IEEE Transactions on Antennas and Propagation*, May 2011

2D NFF “Curved” Leaky Wave Antenna

$$\beta(x) / \beta_0 = \sin \theta_r = \text{constant}$$

θ_r is the radiation angle of the rays emitted by the portion of the LW structure at the abscissa x

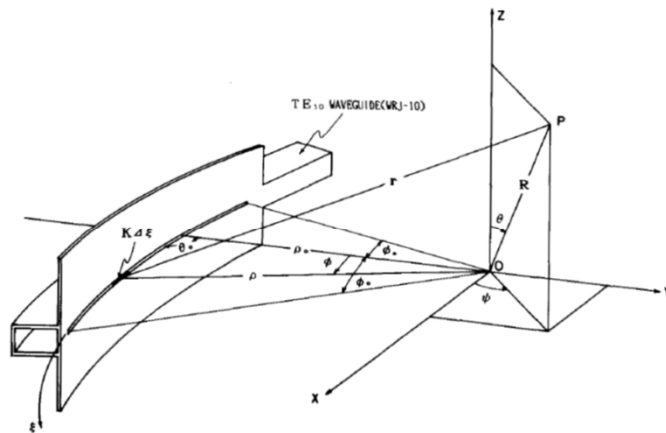
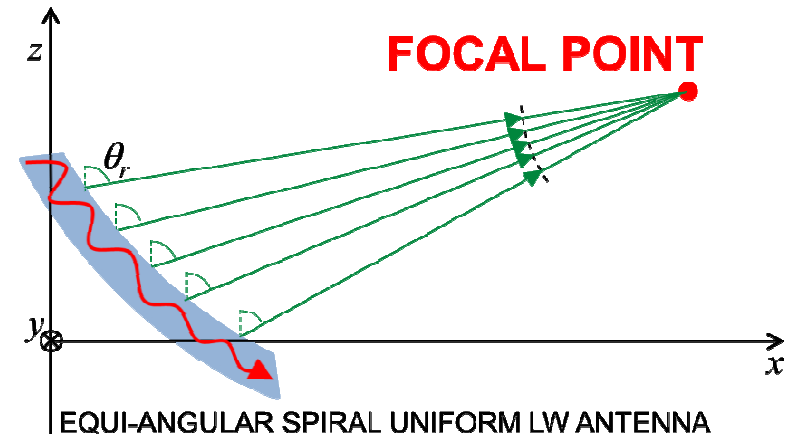
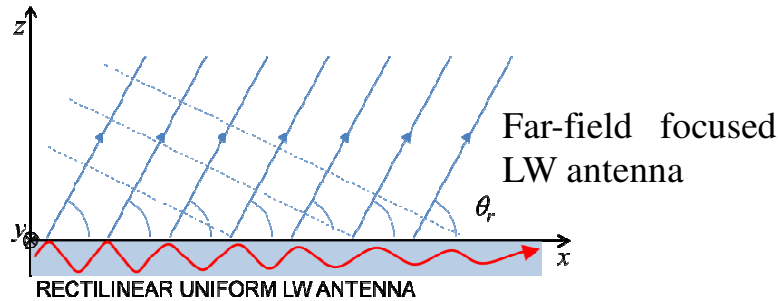
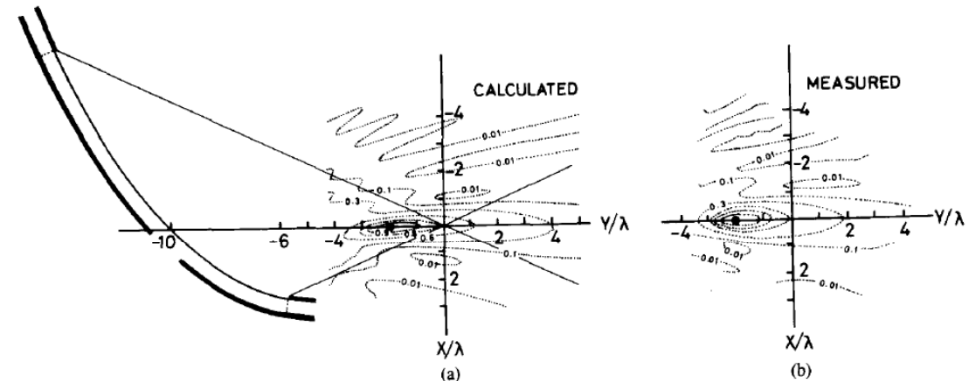

Fig. 1. Equiangular spiral slotted rectangular waveguide (SSRW) radiator and a coordinate system. Slot is located in the xy -plane.

A uniform narrow slot realized into the narrow wall of a bent rectangular waveguide (at 10GHz)



Contour plot of the radiated field at the H-plane. A focal shift exists between the pole of the spiral (selected focal point) and the field maximum point.

I. Ohtera, “Focusing properties of a microwave radiator utilizing a slotted rectangular waveguide”, *IEEE Transactions on Antennas and Propagation*, January 1990

2D-NFF “Tapered” Leaky Wave Antenna

$\theta_r(x)$: position-dependent radiation angle of the rays emitted by the portion of the LW structure at x

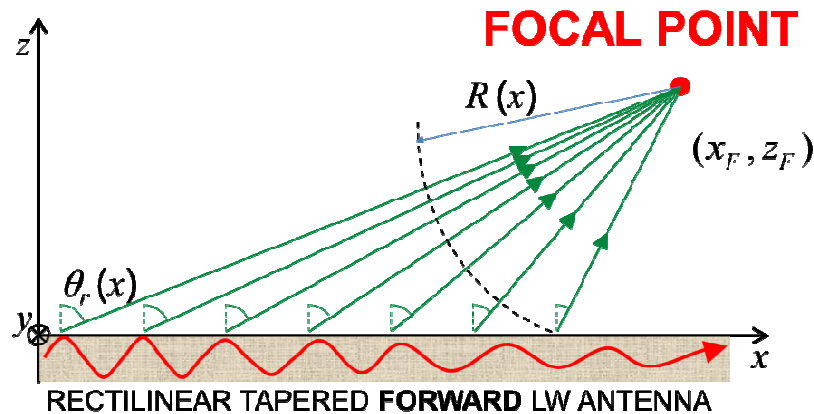

$$\beta(x) / \beta_0 = \sin \theta_r(x) = (x_F - x) / \sqrt{(x_F - x)^2 + z_F^2}$$

$$k(x) / \beta_0 = \beta(x) - j\alpha(x)$$

A proper *tapered* LW structure (geometric and electrical parameters) has to be designed to synthesize the required complex propagation constant of the leaky-mode $\beta(x) - j\alpha(x)$ (phase constant and leakage rate)

$$\beta(x) = -d\varphi(x) / dx = \beta_0 \sin \theta_r(x) \quad \varphi(x) = \beta_0 \sqrt{(x_F - x)^2 + z_F^2} = \beta_0 R(x)$$

$$\varphi(x) - \beta_0 R(x) = 0 \quad \text{All ray contributions sum in-phase at the focal point F}$$

$R(x)$ is the distance between the focal point and the point on the LW antenna at the abscissa x

2D-NFF “Tapered” Leaky Wave Antenna

$\theta_r(x)$: position-dependent radiation angle of the rays emitted by the portion of the LW structure at x

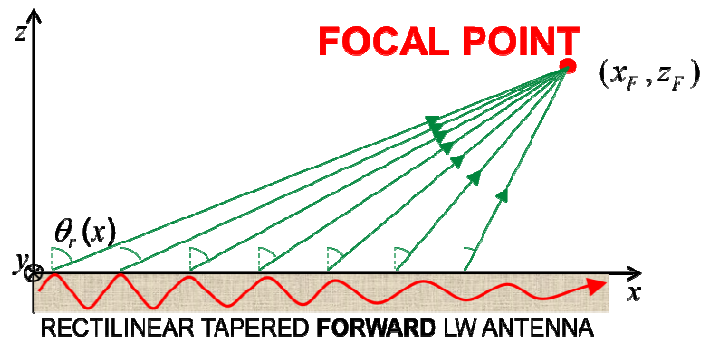

$$\beta(x) / \beta_0 = \sin \theta_r(x) = (x_F - x) / \sqrt{(x_F - x)^2 + z_F^2}$$

$$k(x) / \beta_0 = \beta(x) - j\alpha(x)$$

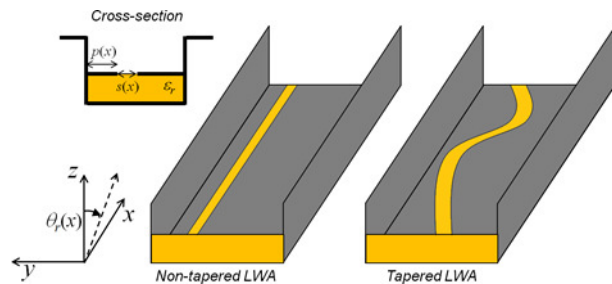

Hybrid waveguide printed-circuit LW antenna technology (20λ guiding structure with a focal point at 25λ , at 5.5 GHz)

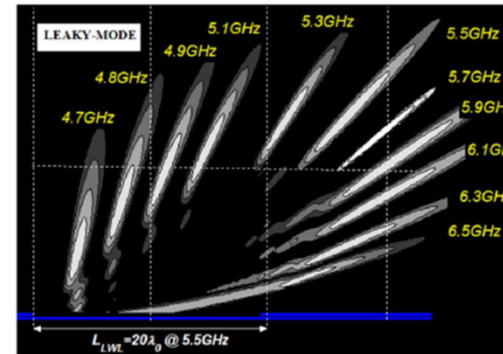

Frequency-based focus scanning

J. L. Gomez-Tornero, F. Quesada-Pereira, A. Alvarez-Melcon, G. Goussetis, A. R. Weily, and Y. J. Guo, “Frequency Steerable Two Dimensional Focusing Using Rectilinear Leaky-Wave Lenses”, *IEEE Transactions on Antennas and Propagation*, February 2011

3D-NFF Modulated Leaky-wave antenna

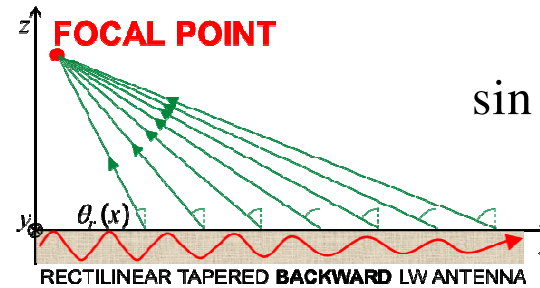
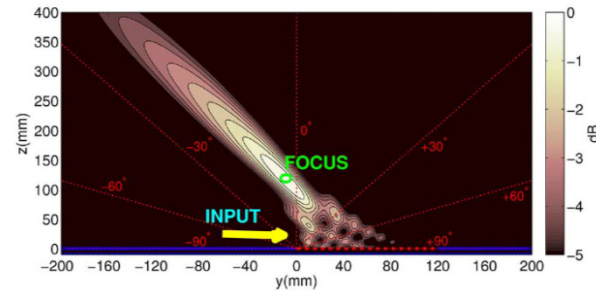

$$\sin \theta_r = \beta / \beta_0 - 2\pi / (P\beta_0) < 0$$

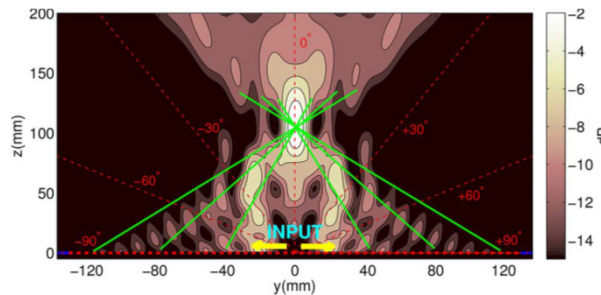

An array of eight 12cm-long and radially oriented **non-uniform sinusoidally modulated half-mode microstrip lines** has been implemented at 15 GHz, to focus the field at 110 mm from the array surface.

The array is feed at its center and radiates a LP field.

The focus width W varies between 15 mm and 20 mm, when considering different longitudinal planes.

The measured focal depth is 60 mm.

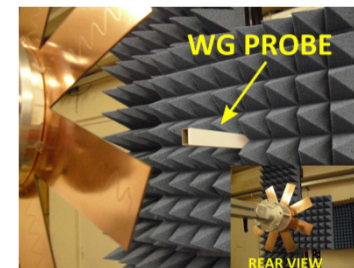
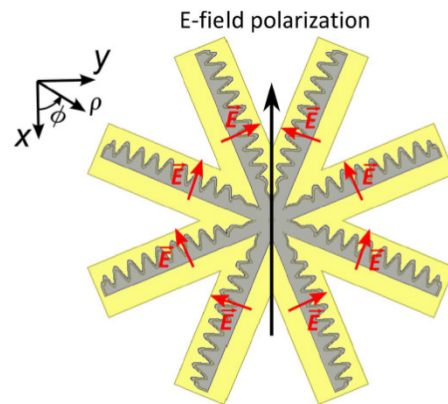

Fig. 8. E -field polarization arrangement for each element of the array (red arrows), and resulting array polarization (black arrow).

A. J. Martinez-Ros, J. L. Gómez-Tornero, V. Losada, F. Mesa, and F. Medina, “Non-Uniform Sinusoidally Modulated Half-Mode Leaky-Wave Lines for Near-Field Focusing Pattern Synthesis”, *IEEE Transactions on Antennas and Propagation*, March 2015

3D-NFF Waveguide Antenna

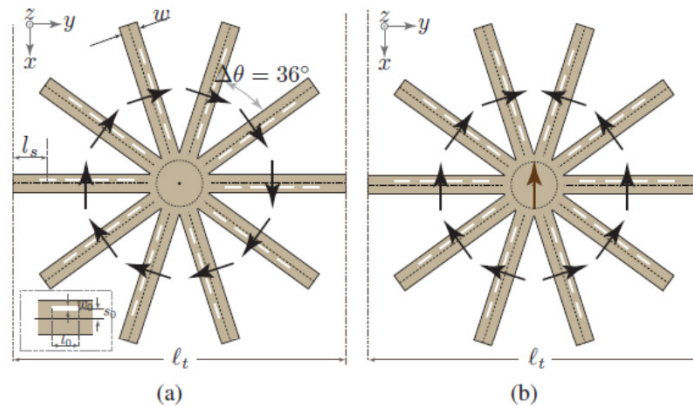

Fig. 1. Illustration of two different star-configuration slot arrays generated by rotating a linear slot waveguide, with a) asymmetric slot configuration, and b) symmetric slot configuration with respect to x -axis. The parameters are: $M = 10$, $z_0 = 10$ cm, $w = 12.2$ mm, $s_0 = 0.425$ mm, $w_0 = 0.4$ mm, $l_0 = 11$ mm, $l_s = 3/4\lambda_g$, and total length of the structure $l_t = 36.84$ cm.

Ten X-band slotted waveguides arranged in a star-configuration allow to achieve a 3D focusing

To avoid a field null at the antenna axis, the left-half and the right-half of the planar array are the mirror image of each other with respect to the E-plane (Fig. 1b)

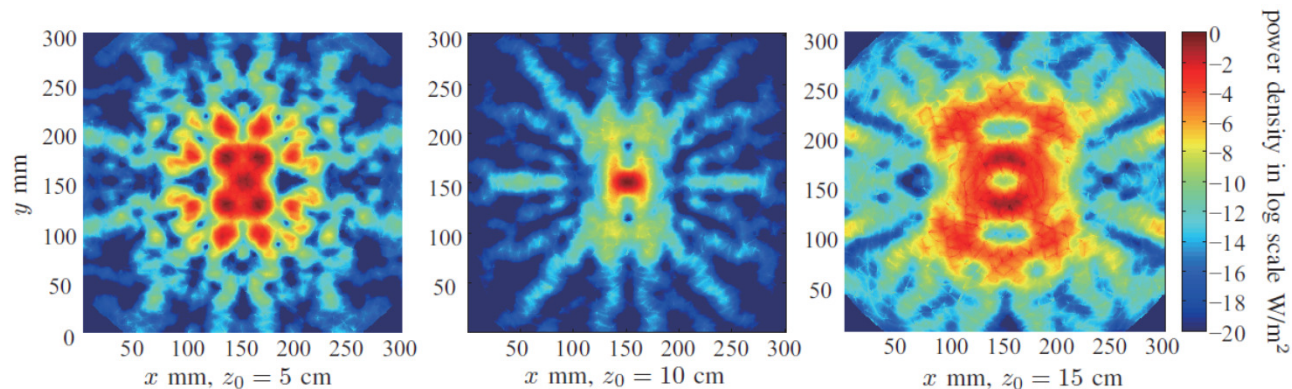

Fig. 3. Power density distribution along in the $x - y$ plane, which is parallel with the plane of the structure, at different locations z_0

M. L. Chen, S. Gupta, Z. L. Ma, and L. J. Jiang, "Linearly polarized near field focused slot-array waveguide", IEEE Antennas and Propagation Symposium, 2014



Conclusions 1/2

Near-field focused antennas are receiving a considerable attention in several applications such as RFID systems, gate access control systems, industrial microwave applications, local hyperthermia, wireless power transfer systems.

In general, a focused antenna is a better solution with respect to conventional far-field focused antennas in all those short-range wireless applications where electrically large microwave antennas can still meet physical size requirements.

The 3D size of the -3 dB focal spot, the focal shift, the level of the secondary lobes around the focal spot region are the metrics used to characterize NFF antennas. The antenna gain and radiation patterns can also be important in some near-field applications as a low far-field radiation is often required to a NFF antenna in addition to the intensification of the radiated field around the focal point.

The polarization and the cross-polar level of the radiated field around the focal spot may require a specific attention in those applications where either the antenna or the scattering object at the focal spot exhibit a substantial dependence on the incident field polarization. Differently from conventional far-field focused antennas, a non-uniform orientation of the radiating element of an antenna array can be effective to improve the focusing performance.



Conclusions 2/2

Due to the strong dependence of the antenna near-field on the surrounding objects/materials (as for example the body tissues in local hyperthermia, or the conductive object an RFID tag is attached to), the synthesis of near-field focused antennas in free-space could lead to a reduction of the system performance with respect to what expected.

Depending on the required focal distance, operating frequency and application scenario, numerical models and synthesis techniques should include the above environment coupling effects in the near-field focused antenna optimization process.

The conjugate-phase technique remains the basic design criteria for near-field focused antennas, and it can represent an effective starting solution of more general multi-objective iterative optimization techniques.

The implementation of the required focusing source excitation requires for proper modifications of the unfocused antenna layout, as for example an adjustment of the feeding network in microstrip arrays, the tuning of the geometrical parameters of the quasi-periodic cells in reflectarrays/transmitarrays, a tapering of the guiding structure in leaky wave antennas.



*Thank you for your
attention !!*

p.nepa@fet.unipi.it